

CONCRETE URBAN STORIES / BELLITALIA®

- p. 004 **CORPORATE /**
AZIENDA
- P. 002 **TIMELINE /**
LA STORIA
- P. 003 **ULTRATENSE CONCRETE® /**
L'ULTRALEGGERO
- P. 004 **PRECIOUS STONES /**
PIETRE PREZIOSE
- P. 005 **ORGANIC /**
SCULTURE
- P. 006 **MATERIALS /**
MATERIALI





CORPORATE /
AZIENDA

WE CREATE /
CREIAMO

WE INNOVATE /
INNOVIAMO

WE CUSTOMIZE /
PERSONALIZZIAMO

WE CARE /
CI PRENDIAMO CURA

WE LOVE /
AMIAMO IL NOSTRO LAVORO

WE CREATE / CREIAMO

BELLITALIA S.R.L IS THE MOST ESTABLISHED, DYNAMIC AND ORIGINAL ITALIAN COMPANY OPERATING IN THE FIELD OF URBAN CONCRETE AND MARBLE AGGREGATES.

THE COMPANY WAS BORN IN THE '60S AS A LEADER IN THE FIELD OF PRECAST CONCRETE. NEW CHALLENGES HAVE ALLOWED THE COMPANY TO CONSTANTLY EVOLVE AND IT HAS QUICKLY DEVELOPED A WIDESPREAD DISTRIBUTION WITHIN THE ITALIAN TERRITORY.

DURING THE '80S **BELLITALIA**® COMMITTED TO GROW IN THE URBAN FURNISHINGS SECTOR, THANKS TO A RESTRUCTURING OF THE ORGANISATION AND PRODUCTION, WHICH WAS DESTINED TO CHANGE THE FACE OF THE COMPANY.

THE DEBUT OF THE FIRST COLLECTION ENTIRELY DEDICATED TO FURNITURE IN URBAN CENTERS BECAME THE FAMOUS *CLASSIC LINE*, STILL RECOGNISABLE WORLDWIDE IN THE PLANTERS' FAMOUS SHAPE AND IN THE UNMISTAKABLE COPPER BAND, ON CONCRETE BOLLARDS, ON BENCHES, ON LITTER BINS, BICYCLE



RACKS AND TREE GRIDS.

IT IS THIS THAT HAS REVOLUTIONISED AND GIVEN FORM AND CONTENT TO THE NEW CONCEPT OF URBAN FURNITURE, INTENDED AS A NEW WAY OF LIVING THE PUBLIC SPACES OF THE CITY.

OVER TIME THE LINES HAVE MULTIPLIED AND NEW MATERIALS SUCH AS STEEL, STAINLESS STEEL, CAST IRON AND WOOD HAVE BEEN ADDED TO MATCH THE CONCRETE, CREATING WHOLE NEW COLLECTIONS.

THE HIGHLIGHT OF THE **BELLITALIA®** PRODUCTION CAME IN 2006 WITH THE BIRTH OF THE *PRECIOUS STONES* LINE, A FULL RANGE OF PRODUCTS MADE OF MARBLE AGGREGATES THAT IS STILL UNIQUE ON THE MARKET, WHOSE RICH COLOUR, TEXTURE AND FINISHING CHARACTERISE THEM AS BENCHMARKS ON THE INTERNATIONAL MARKET.

IN 2015 **BELLITALIA®** BEGAN A MAJOR NEW CHALLENGE BY DEVELOPING THE INNOVATIVE FORMULA *ULTRATENSE CONCRETE®*. THIS NEW MATERIAL MAKES IT POSSIBLE TO PUSH DESIGN TO THE EXTREME, TO INCREASINGLY COMPLEX AND INNOVATIVE LINES, TO SHAPE OBJECTS THAT WILL ONCE AGAIN MARK A STEP IN THE HISTORY OF URBAN DESIGN.



BELLITALIA S.R.L. È LA PIÙ CONSOLIDATA E ALLO STESSO TEMPO DINAMICA E ORIGINALE REALTÀ INDUSTRIALE ITALIANA OPERANTE NEL SETTORE DELL'ARREDO URBANO IN CEMENTO E IN PIETRE DI MARMO.

NASCE NEGLI ANNI '60 COME AZIENDA LEADER NEL SETTORE DEI MANUFATTI IN CEMENTO PER LE COSTRUZIONI. LE CONTINUE SFIDE PERMETTONO ALL'AZIENDA DI EVOLVERSI COSTANTEMENTE E DI RAGGIUNGERE IN BREVE TEMPO UNA DIFFUSIONE CAPILLARE SUL TERRITORIO ITALIANO.

DURANTE GLI ANNI '80 CRESCE L'IMPEGNO DI **BELLITALIA®** NEL SETTORE DELL'ARREDO URBANO, IN SEGUITO ALL'AVVIO DI UNA RISTRUTTURAZIONE ORGANIZZATIVA E PRODUTTIVA DESTINATA A CAMBIARE IL VOLTO DELL'AZIENDA.

L'ESORDIO DELLA PRIMA LINEA DI PRODOTTI INTERAMENTE DEDICATI ALL'ARREDO DEI CENTRI URBANI AVVIENE CON LA CELEBRE *LINEA CLASSICA*, ANCORA OGGI RICONOSCIBILE NELLE FIORIERE FAMOSE IN TUTTO IL MONDO PER LE LORO FORME E L'INCONFONDIBILE FASCIA IN RAME, NEI DISSUASORI IN CALCESTRUZZO, NELLE PANCHINE, NEI CESTONI PORTARIFIUTI, NEI PORTABICICLETTE, NELLE GRIGLIE PER ALBERI.

SI TRATTA DI UNA VERA E PROPRIA RIVOLUZIONE CHE CONCORRE





A DARE FORMA E CONTENUTO AL NUOVO CONCETTO DI ARREDO URBANO, INTESO COME UN NUOVO MODO DI ABITARE GLI SPAZI PUBBLICI DELLE CITTÀ.

NEL TEMPO LE LINEE SI MOLTIPLICANO E NUOVI MATERIALI QUALI L'ACCIAIO, L'INOX, LA GHISA E IL LEGNO SI ABBINANO AL CALCESTRUZZO DANDO VITA AD INTERE NUOVE COLLEZIONI.

IL FIORE ALL'OCCHIELLO DELLA PRODUZIONE **BELLITALIA®** ARRIVA NEL 2006 CON LA NASCITA DELLA LINEA *PIETRE PREZIOSE*, UNA GAMMA COMPLETA DI ARTICOLI REALIZZATI IN PIETRE DI MARMO TUTTORA UNICI SUL MERCATO, LA CUI RICCHEZZA CROMATICA, DI TEXTURE E FINITURA LI CARATTERIZZA COME BENCHMARKS SUL MERCATO INTERNAZIONALE.

NEL 2015 BELLITALIA® INIZIA UNA NUOVA IMPORTANTE SFIDA SVILUPPANDO L'INNOVATIVA FORMULA DELL'*ULTRATENSE CONCRETE®*.

QUESTO NUOVO MATERIALE PERMETTE DI SPINGERE IL DESIGN ALL'ESTREMO, VERSO LINEE SEMPRE PIÙ COMPLESSE E INNOVATIVE, PER DARE FORMA A OGGETTI CHE SEGNERANNO ANCORA UNA VOLTA IL PASSO NELLA STORIA DELL'ARREDO URBANO.





WE INNOVATE / INNOVIAMO

THE INNOVATION AND CONTINUOUS IMPROVEMENT OF INDUSTRIAL TECHNOLOGIES IS ONE OF THE CHALLENGES AND ONE OF THE HALLMARKS OF **BELLITALIA®**.

DEVELOPING THE ENTIRE TECHNOLOGY INTERNALLY (FROM THE DESIGN, MACHINERY AND MOULDS TO THE PRODUCTION OF EACH SINGLE ARTIFACT), THE COMPANY ENSURES ACCURATE CONTROL OVER EVERY STAGE OF PRODUCTION OF THE PIECES. THIS CONTROL IS AN ASSURANCE OF QUALITY THAT ALLOWS **BELLITALIA®** TO ACHIEVE EXCELLENCE IN EVERY OBJECT AND DETAIL.

THE SKETCHES AND IDEAS OF THE DESIGNERS ARE SUBJECTED TO CAREFUL CONTROLS AND CHECKS USING THE MOST CONTEMPORARY 3D MODELING TECHNOLOGIES, WHICH PROJECT MANAGEMENT AND DESIGN TEAMS HAVE AT THEIR DISPOSAL.

THE PRINCIPAL ELEMENT OF STREET FURNITURE IS DESIGN, ON WHICH **BELLITALIA®** HAS ALWAYS FOCUSED. FOR THIS REASON THE COMPANY IS ADVISED BY INTERNATIONALLY RENOWNED

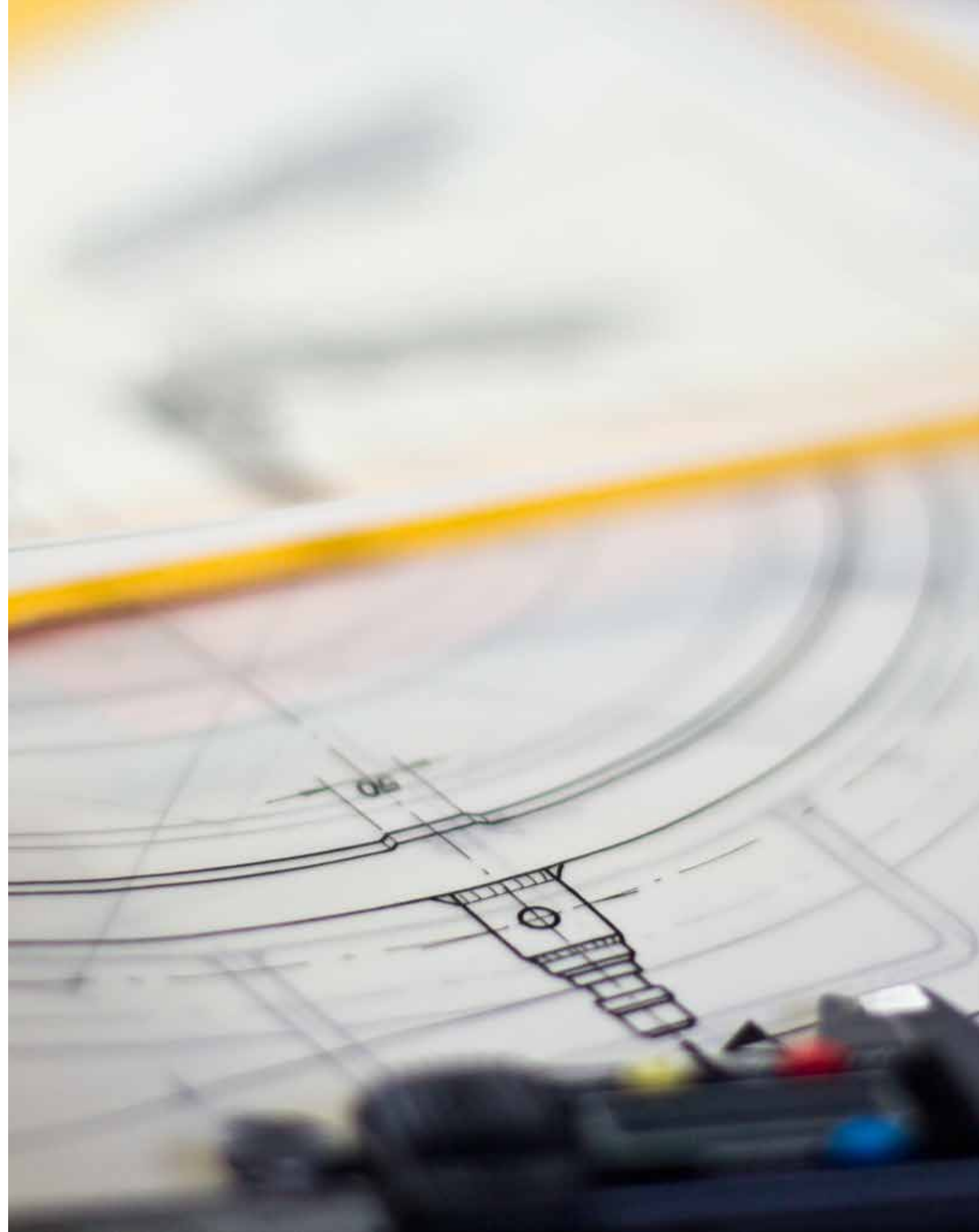

ARCHITECTS AND WORKS IN COLLABORATION WITH THE MOST ADVANCED RESEARCH LABORATORIES IN ITALY.

BELLITALIA® IS CONVINCED THAT ONLY A MULTI-DISCIPLINARY TEAM OF THE HIGHEST LEVEL IS ABLE TO MEET THE CHALLENGES OF A MARKET IN PROFOUND TRANSFORMATION. THAT IS WHY CONTINUOUS RESEARCH HAS RESULTED IN A RECENT COLLABORATION WITH THE DEPARTMENT OF MATERIALS, ENVIRONMENTAL SCIENCES AND URBAN PLANNING AT THE POLYTECHNIC UNIVERSITY OF MARCHE, **SIMAU**.

THE DEPARTMENT, AMONG OTHER AREAS OF RESEARCH, DEALS WITH THE DEVELOPMENT OF INNOVATIVE MATERIALS FOR PRODUCTION PROCESSES, COMPATIBLE WITH THE NEEDS OF THE ENVIRONMENT. IT WORKS WITH THE INTENTION OF PROMOTING A STRONG INTERACTION WITH THE DIFFERENT COMPONENTS OF PUBLIC ADMINISTRATION, INDUSTRY AND RESEARCH INSTITUTIONS, THROUGH THE DEVELOPMENT OF RESEARCH AGREEMENTS, COOPERATION AND TECHNICAL-SCIENTIFIC CONSULTANCY. FROM THE INVOLVEMENT OF THE UNIVERSITY IN THE ANALYSIS AND SOLUTION OF REAL PROBLEMS THAT DIRECTLY AFFECT SOCIETY, RESEARCH CAN PROVIDE STIMULUS AND VERIFICATION.

WITHIN THIS FRAMEWORK, THE PARTNERSHIP WITH **SIMAU**, WHILE ALLOWING THE PUSH OF **BELLITALIA®** DESIGN TOWARDS EVER-INCREASINGLY INTERESTING IDEAS, WILL FINANCE YOUNG ITALIAN RESEARCHERS ON AREAS OF RESEARCH AND DEVELOPMENT AND THUS CONTRIBUTING TO THE ECONOMIC AND CULTURAL GROWTH OF OUR COUNTRY.



L'INNOVAZIONE ED IL CONTINUO MIGLIORAMENTO DELLE TECNOLOGIE INDUSTRIALI È UNA DELLE SFIDE E DEI SEGNI DISTINTIVI DI **BELLITALIA®**.

SVILUPPANDO INTERNAMENTE L'INTERA TECNOLOGIA (DALLA PROGETTAZIONE, AI MACCHINARI, AGLI STAMPI FINO ALLA REALIZZAZIONE DI OGNI SINGOLO MANUFATTO), L'AZIENDA GARANTISCE IL CONTROLLO ACCURATO DI OGNI FASE DELLA LAVORAZIONE DEI PRODOTTI. QUESTO CONTROLLO È UN'ASSICURAZIONE DI QUALITÀ CHE PERMETTE A **BELLITALIA®** DI RAGGIUNGERE L'ECCELLENZA IN OGNI OGGETTO E DETTAGLIO.

GLI SCHIZZI E LE IDEE DEI DESIGNERS VENGONO SOTTOPOSTE A CONTROLLI ACCURATI E PROGRESSIVE VERIFICHE UTILIZZANDO LE PIÙ CONTEMPORANEE TECNOLOGIE DELLA MODELLAZIONE 3D, DI CUI DISPONGONO LE SQUADRE DI PROJECT E DESIGN MANAGEMENT.

IL DESIGN NEL CAMPO DELL'ARREDO URBANO È UN ELEMENTO PRIMARIO E VERSO DI ESSO **BELLITALIA®** RIVOLGE DA SEMPRE

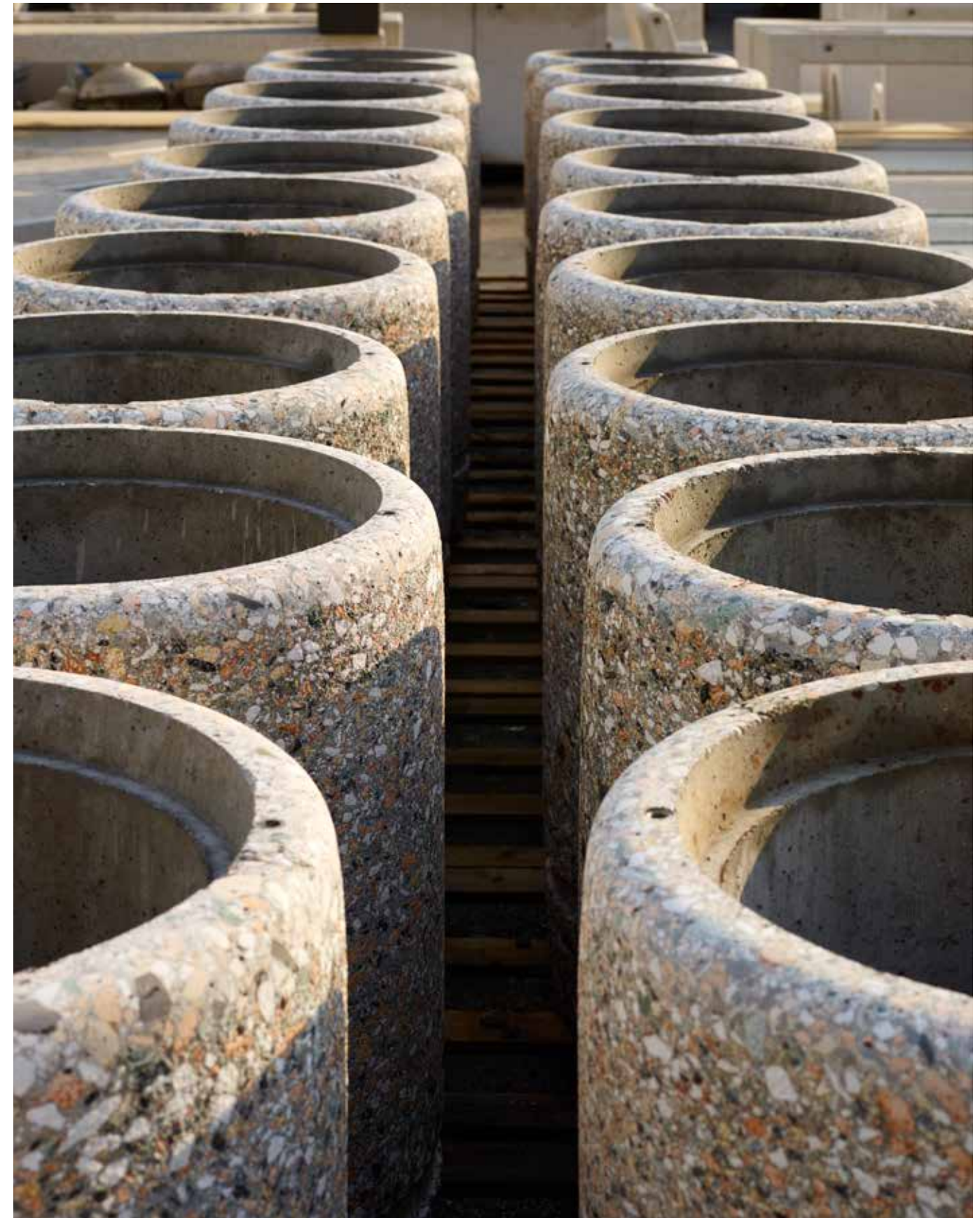

LA PROPRIA ATTENZIONE. PER QUESTO MOTIVO SI AVVALE DELLA CONSULENZA DI ARCHITETTI DI FAMA INTERNAZIONALE E DELLA COLLABORAZIONE CON I LABORATORI DI RICERCA PIÙ ALL'AVANGUARDIA IN ITALIA.

BELLITALIA® È CONVINTA CHE SOLO UN TEAM MULTIDISCIPLINARE DI ALTISSIMO LIVELLO POSSA ESSERE IN GRADO DI RISPONDERE ALLE SFIDE DI UN MERCATO IN PROFONDA TRASFORMAZIONE.

E' PER QUESTO CHE LA RICERCA CONTINUA È SFOCIATA IN UNA RECENTE COLLABORAZIONE CON IL DIPARTIMENTO DI SCIENZE E INGEGNERIA DELLA MATERIA, DELL'AMBIENTE ED URBANISTICA DELL'UNIVERSITÀ POLITECNICA DELLE MARCHE, **SIMAU**.

IL DIPARTIMENTO, TRA ALTRI AMBITI DI RICERCA, SI OCCUPA DELLO SVILUPPO DI MATERIALI INNOVATIVI PER I PROCESSI PRODUTTIVI, COMPATIBILI CON LE ESIGENZE DELL'AMBIENTE. ESSO OPERA CON L'INTENTO DI FAVORIRE UNA FORTE INTERAZIONE CON LE DIVERSE COMPONENTI DELLE AMMINISTRAZIONI PUBBLICHE, DELL'INDUSTRIA E DEGLI ENTI DI RICERCA, MEDIANTE LO SVILUPPO DI CONVENZIONI DI RICERCA, COLLABORAZIONI E CONSULENZE TECNICO-SCIENTIFICHE, NELLA CONSAPEVOLEZZA CHE LA RICERCA POSSA TROVARE NUOVE OCCASIONI DI STIMOLO E DI VERIFICA PROPRIO DAL COINVOLGIMENTO DELL'UNIVERSITÀ NELL'ANALISI E NELLA SOLUZIONE DEI PROBLEMI REALI E CHE INTERESSANO DIRETTAMENTE LA SOCIETÀ.



IN TALE QUADRO DI RIFERIMENTO, LA COLLABORAZIONE CON **SIMAU**, PERMETTENDO DI SPINGERE IL DESIGN **BELLITALIA®** VERSO LINEE SEMPRE PIÙ INTERESSANTI, CONSENTIRÀ DI FINANZIARE GIOVANI RICERCATORI ITALIANI SU SETTORI DI RICERCA E SVILUPPO CONTRIBUENDO COSÌ ALLA CRESCITA ECONOMICA E CULTURALE DEL NOSTRO PAESE.



WE CUSTOMIZE / PERSONALIZZIAMO

BELLITALIA® HAS DEVELOPED A TECHNICAL CAPABILITY AND DESIGN FLEXIBILITY THAT ENABLES IT TO ACHIEVE CUSTOMISED PRODUCTS EVEN ON THE MOST SPECIFIC CUSTOMER REQUIREMENTS.

YEARS OF CONCRETE AND CONGLOMERATE PROCESSING, ALONGSIDE THE IMPLEMENTATION OF NUMEROUS SPECIAL PROJECTS, HAVE ENABLED THE COMPANY TO INCREASE ITS RESULTS FROM THE POINT OF VIEW OF DESIGN, QUALITY AND DURABILITY, WHILE WIDENING COMMUNICATION CHANNELS WITH THE CUSTOMER.

THE PRO-ACTIVENESS IN THE DEVELOPMENT OF TAILOR-MADE PROJECTS HAS THEREFORE BECOME AN INTEGRAL PART OF THE KNOW-HOW OF THE COMPANY, WITH AN INTERNAL WORKING TEAM SPECIFICALLY DEDICATED TO THE INTERACTION WITH THE CUSTOMER AND TO THE STUDY OF PARTICULAR PROJECTS.

THIS OPEN-MINDEDNESS IS CONSIDERED A GREAT ATTITUDE THAT THE COMPANY USES TO COMPETE AND GROW IN THEIR SKILLS, DISPLAYING AN IMAGE OF GREAT FLEXIBILITY AND ADDED VALUE.





BELLITALIA® HA SVILUPPATO UNA CAPACITÀ TECNICA E UNA FLESSIBILITÀ PROGETTUALE CHE LE CONSENTONO DI REALIZZARE PRODOTTI PERSONALIZZATI ANCHE SU SPECIFICHE RICHIESTE DEL CLIENTE.

ANNI DI LAVORAZIONE DEL CALCESTRUZZO E DEI CONGLOMERATI E LA REALIZZAZIONE DI NUMEROSI PROGETTI SPECIALI, HANNO PERMESSO ALL'AZIENDA DI INCREMENTARE I PROPRI RISULTATI DA UN PUNTO DI VISTA DI DESIGN, DI QUALITÀ E DUREVOLEZZA, AMPLIANDO I CANALI DI ASCOLTO DEL CLIENTE.

LA REATTIVITÀ NELLO SVILUPPO DI PROGETTI TAILOR-MADE È DIVENTATA QUINDI PARTE INTEGRANTE DEL KNOW-HOW DELL'AZIENDA CON UNA SQUADRA DI LAVORO INTERNA SPECIFICAMENTE DEDICATA ALL'INTERAZIONE COL CLIENTE E ALLO STUDIO DI PROGETTI PARTICOLARI.

QUESTA APERTURA VIENE CONSIDERATA UNA GRANDE OPPORTUNITÀ CHE L'AZIENDA COGLIE PER CONFRONTARSI E CRESCERE NELLE PROPRIE COMPETENZE, OFFRENDO ALL'ESTERNO UN'IMMAGINE DI GRANDE FLESSIBILITÀ E VALORE AGGIUNTO.





VIETATO FUMARE

WE CARE / CI PRENDIAMO CURA

BELLITALIA® IS PARTICULARLY ATTENTIVE TO SUSTAINABILITY, THE ENVIRONMENT AND CLEAN ENERGY BY USING A SYSTEM OF PHOTOVOLTAIC PANELS THAT COVER THE ENTIRE ROOF OF THE OFFICES.

THE INERT MATERIALS **BELLITALIA**® USES FOR THE PRODUCTION OF CONCRETE ARE DERIVED LOCALLY, COMING FROM THE AREA OF THE DOLOMITES SURROUNDING THE COMPANY, THEREFORE FUEL CONSUMPTION AND **CO₂** EMISSIONS ARISING FROM THEIR TRANSPORTATION ARE MINIMISED.

MATERIALS FROM DIFFERENT ITALIAN QUARRIES, WHICH WOULD OTHERWISE HAVE BEEN DISCARDED DURING THE PROCESSING OF THE MARBLE, ARE RECYCLED AND USED FOR THE PRODUCTION OF THE PRECIOUS STONES CONGLOMERATE.

THIS ECONOMICAL USE OF RESOURCES IN THE PRODUCTION PROCESS, SUCH AS THE PREFERENCE TO USE PURIFIED RAINWATER BEFORE THAT FROM THE RESERVOIR, THE REDUCTION OF EMISSIONS, THE USE OF RECYCLED MATERIALS, AND THE



USE OF WOOD FROM CERTIFIED FORESTS, ALL REPRESENT THE STRONG COMMITMENT OF **BELLITALIA**®'S SUBSTANTIAL CONTRIBUTION TO ENVIRONMENTAL SUSTAINABILITY. THE CONCRETE IS ALSO A VERSATILE MATERIAL, DURABLE AND 100% RECYCLABLE, AND THE NUMBER OF TIMES THIS COMPOUND CAN BE REUSED IS ALMOST INFINITE. EMPLOYING IT FOR THEIR PIECES, **BELLITALIA**® USES EFFICIENT TECHNOLOGY FOR THE ENTIRE LIFE CYCLE OF THE PRODUCT.



BELLITALIA® È PARTICOLARMENTE ATTENTA ALLA SOSTENIBILITÀ E ALL'AMBIENTE E UTILIZZA ENERGIA PULITA GRAZIE A UN SISTEMA DI PANNELLI FOTOVOLTAICI CHE RIVESTONO L'INTERA COPERTURA DEGLI UFFICI.

GLI INERTI CHE **BELLITALIA**® UTILIZZA PER LA PRODUZIONE DEL CALCESTRUZZO SONO A CHILOMETRO ZERO, PROVENENDO DALLA ZONA DOLOMITICA CIRCOSTANTE ALL'AZIENDA, PERTANTO CONSUMI ED EMISSIONI DI **CO2** DERIVANTI DAL LORO TRASPORTO SONO RIDOTTI AL MINIMO.

PER LA PRODUZIONE DEL CONGLOMERATO DEL TIPO PIETRE PREZIOSE VENGONO ADOTTATE TECNICHE DI RECYCLING DELLE LAVORAZIONI DEL MARMO, IMPIEGANDO MATERIALI PROVENIENTI DA DIFFERENTI CAVE ITALIANE, CHE ALTRIMENTI VERREBBERO



SCARTATI.
QUESTO PARSIMONIOSO UTILIZZO DELLE RISORSE NEL PROCESSO PRODUTTIVO, COME LA PREFERENZA NELL'UTILIZZO DELL'ACQUA PIOVANA DEPURATA PRIMA DI QUELLA DELL'ACQUEDOTTO, LA RIDUZIONE DELLE EMISSIONI, L'IMPIEGO DI MATERIALE DI RECUPERO, E L'UTILIZZO DI LEGNAMI PROVENIENTI DA FORESTE CERTIFICATE, RAPPRESENTANO IL FORTE IMPEGNO DI **BELLITALIA**[®] PER CONTRIBUIRE IN MANIERA SOSTANZIALE ALLA SOSTENIBILITÀ AMBIENTALE.
IL CALCESTRUZZO È INOLTRE UN MATERIALE VERSATILE, DUREVOLE E RICICLABILE AL 100% E IL NUMERO DI CICLI DI RIUTILIZZO DI QUESTO COMPOSTO È PRESSOCHÉ INFINITO. IMPIEGANDOLO PER I PROPRI MANUFATTI, **BELLITALIA**[®] SFRUTTA UNA TECNOLOGIA EFFICIENTE PER L'INTERO CICLO DI VITA DEL PRODOTTO.





WE LOVE / AMIAMO IL NOSTRO LAVORO

THE PASSION THAT DRIVES EACH NEW PROJECT IS THE ENERGY, THE FUEL THAT DRIVES THE COMPANY TO LAUNCH ITSELF AT NEW CHALLENGES. EACH OF THE PEOPLE WITHIN THE COMPANY CONTRIBUTES TO THE SUCCESS OF THE BRAND **BELLITALIA®** WITH LOVE AND DEDICATION.

AT ALL LEVELS OF THE PRODUCTION PROCESS, EACH PRODUCT IS DEVELOPED AND DESIGNED TO SIMPLIFY THE WORK FOR THE CLIENT, WITH THE GUARANTEE OF GETTING THE MAXIMUM DURABILITY AND QUALITY, REDUCING MAINTENANCE TO A MINIMUM, AND ALLOWING EASE OF ASSEMBLY, PLACEMENT AND POSITIONING, BOTH WITH REGARD TO THE SINGLE PRODUCT, AND THAT OF THE COMPONENTS.

IT IS OUR PRODUCTS THAT TALK THROUGH THE VALUE OF THE MATERIALS, THE BEAUTY OF THE FINISHES AND CRAFTSMANSHIP, ATTENTION TO DETAIL, FUNCTIONALITY AND CUSTOMISATION OF MODELS, ENVIRONMENTAL SUSTAINABILITY, INNOVATION AND OPENNESS TO THE YOUNGER GENERATION: ALL VALUES IN WHICH WE RECOGNIZE AND WHICH HELP TO MAKE **BELLITALIA®** PRODUCTS UNIQUE ELEMENTS OF A MADE IN ITALY, THAT STANDS OUT IN THE WORLD.



LA PASSIONE CHE ANIMA OGNI NUOVO PROGETTO È L'ENERGIA, IL CARBURANTE CHE SPINGE L'AZIENDA A LANCIARSI IN NUOVE SFIDE. UN'AZIENDA FATTA DI PERSONE, OGNUNA DELLE QUALI CON AMORE E DEDIZIONE CONTRIBUISCE AL SUCCESSO DEL BRAND **BELLITALIA®**.

A TUTTI I LIVELLI DEL PROCESSO PRODUTTIVO OGNI PRODOTTO VIENE STUDIATO E PROGETTATO PER SEMPLIFICARE AL MASSIMO IL LAVORO AL CLIENTE, CON LA GARANZIA DI OTTENERE LA MASSIMA DUREVOLEZZA E QUALITÀ, RIDURRE AL MINIMO LA MANUTENZIONE, PERMETTERE LA FACILITÀ DI ASSEMBLAGGIO, COLLOCAZIONE E POSIZIONAMENTO, SIA PER QUANTO RIGUARDA IL SINGOLO MANUFATTO, CHE PER I COMPONENTI.

SONO I NOSTRI PRODOTTI A PARLARE ATTRAVERSO IL PREGIO DEI MATERIALI, LA BELLEZZA DELLE FINITURE E DELLE LAVORAZIONI ARTIGIANALI, LA CURA DEL DETTAGLIO, LA FUNZIONALITÀ E PERSONALIZZAZIONE DEI MODELLI, LA SOSTENIBILITÀ AMBIENTALE, L'INNOVAZIONE E L'APERTURA VERSO LE GIOVANI GENERAZIONI: TUTTI VALORI IN CUI CI RICONOSCIAMO E CHE CONTRIBUISCONO A RENDERE I PRODOTTI **BELLITALIA®** ELEMENTI UNICI DI UN MADE IN ITALY CHE SI DISTINGUE A LIVELLO MONDIALE.







TIMELINE /
LA STORIA

1962



BIRTH OF THE COMPANY, A MANUFACTURER OF PRECAST CONCRETE /
NASCITA DELLA SOCIETÀ, PRODUTTRICE DI PREFABBRICATI IN CEMENTO.

1988



BELLITALIA FURNITURE BECOMES WORLD FAMOUS. SO BEGINS EXPORT /
L'ARREDO BELLITALIA DIVENTA FAMOSO NEL MONDO. SI DÀ IL VIA ALL'EXPORT.



THE FIRST LICENSES ARE SOLD FOR KNOW-HOW AND MOULDS IN EUROPE, VENEZUELA, BRAZIL AND TURKEY /
SI VENDONO LE PRIME LICENZE PER KNOW-HOW E STAMPI IN EUROPA, VENEZUELA, BRASILE E TURCHIA.

2003



OUR PRIDE: PRECIOUS STONES LINE IS BORN /
IL FIORE ALL'OCCHIELLO: NASCONO LE PIETRE PREZIOSE.

2013

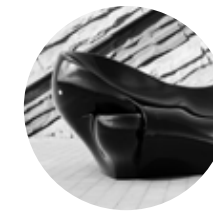

READY FOR NEW CHALLENGES: THE BIRTH OF THE ORGANIC LINE. COMPLEX SHAPES AND BOLD FINISHES /
LA SFIDA È SEMPRE PIÙ ACCATTIVANTE: NASCE LA LINEA ORGANIC. FORME COMPLESSE E FINITURE AUDACI.

1986



THE CONCEPT OF STREET FURNITURE IS BORN, ALONG WITH THE CLASSIC LINE /
NASCE IL CONCETTO DI ARREDO URBANO, NASCE LA LINEA CLASSICA.

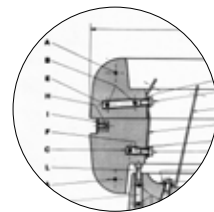

REGISTRATION OF THE FIRST PATENTS /
REGISTRAZIONE DEI PRIMI BREVETTI INDUSTRIALI.

2000



THE FURNITURE RANGE IS COMPLETED WITH THE METAL LINES MADE OF CAST IRON AND STEEL /
LA GAMMA ARREDO SI COMPLETA CON LE LINEE METAL IN GHISA E ACCIAIO.

2006



PRODUCED THE FIRST LITTER BIN ATLANTE. NOW HEADING TOWARDS 18,000 UNITS SOLD /
VIENE PRODOTTO IL PRIMO CESTONE ATLANTE. RAGGIUNGERÀ I 18.000 PEZZI VENDUTI.

2015



AN EXTRAORDINARY INVENTION: ULTRATENSE CONCRETE®. HIGH-TECH CEMENT AT THE HIGHEST DEGREE OF EVOLUTION /
UNA STRAORDINARIA INVENZIONE: L'ULTRATENSE CONCRETE®. IL CEMENTO HIGH-TECH AL MASSIMO GRADO DI EVOLUZIONE.



A roll of Ultratense Concrete fiber mesh is shown on a wooden surface. The mesh is composed of numerous thin, dark fibers. In the background, there is a blurred roll of a similar material, but with a different color (lighter, possibly white or light brown).

ULTRATENSE CONCRETE® /
L'ULTRALEGGERO

ULTRATENSE CONCRETE® / L'ULTRALEGGERO

ULTRATENSE CONCRETE® IS A REGISTERED TRADEMARK EXCLUSIVELY ON THE MARKET FOR BELLITALIA. IT WAS DEVELOPED IN COLLABORATION WITH THE RESEARCHERS AT THE DEPARTMENT OF MATERIALS, ENVIRONMENTAL SCIENCES AND URBAN PLANNING OF THE POLYTECHNIC UNIVERSITY OF MARCHE (**SIMAU**), AND INTERNATIONALLY RENOWNED DESIGN STUDIOS.

AN INNOVATIVE CONCRETE MATERIAL, MADE WITH THE LATEST CUTTING EDGE TECHNOLOGY, **ULTRATENSE CONCRETE®** IS THE FUTURE.

EXTREMELY DUCTILE AND CAPABLE OF ACHIEVING VERY THIN LAYERS, IT CAN ALSO BE CAST IN MORE COMPLEX FORMS, THANKS TO ITS CAPACITY TO SLIDE AND FILL EVEN THE MOST CRAMPED OF SPACES.

UTC® IS A MATERIAL WITH SUPERIOR MECHANICAL CHARACTERISTICS EVEN WITHOUT THE USE OF COMPLEX INTERNAL REINFORCEMENTS.

THIS PECULIARITY ALLOWS FOR A LARGE AMOUNT OF CREATIVE FREEDOM AT THE MODELLING STAGE, PERMITTING A GENERATION

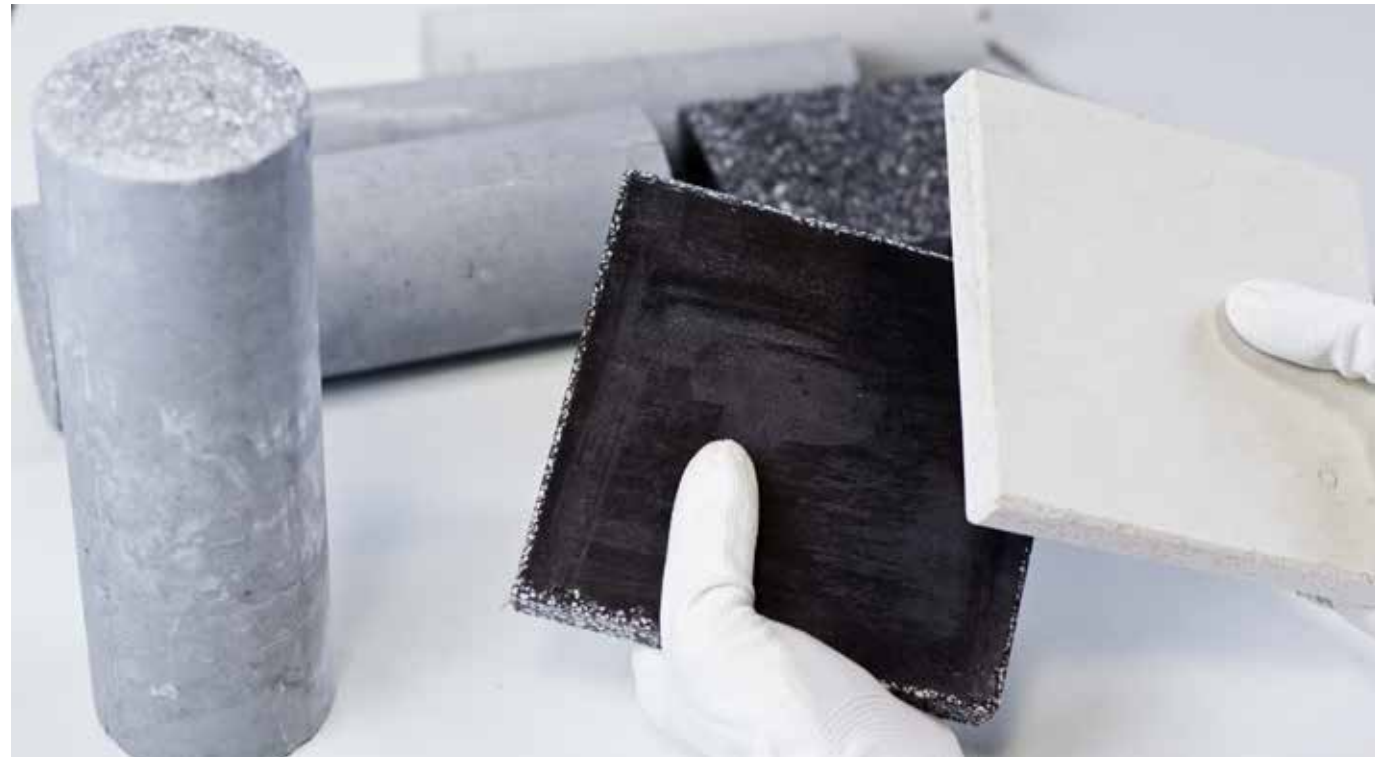



OF PRODUCTS WITH VERY THINLY LAYERED SURFACES, CURVED THREE-DIMENSIONAL SPACE AND ABLE TO MEET THE NEEDS OF THE MOST ENTERPRISING DESIGNERS AND THE MOST COMPLEX ENVIRONMENTAL FACTORS.

THESE CHARACTERISTICS HAVE BEEN AMPLIFIED THROUGH A DESIGN THAT ALLOWS THEM TO SHAPE PIECES OF STREET FURNITURE THAT WERE PREVIOUSLY UNTHINKABLE, THAT WILL TRANSFORM THE WAY WE LIVE AND INTERACT IN PUBLIC SPACES IN THE CITY.

THE FINAL COLOURS DERIVED FROM THE ADDITION OF PIGMENTS DURING THE MIXING BECOME AN INTRINSIC PART OF THE MATERIAL ENSURING A LONG-LASTING RESISTANCE.

UTC® ALSO MAINTAINS A DEGREE OF INFINITE RECYCLING, THANKS TO THE NATURE OF THE BASE FORMED BY CEMENT AND AGGREGATES OF THE BEST QUALITY, OBTAINED FROM QUARRIES

AND CERTIFIED BY CONTROLLED PROCESSES.



ULTRATENSE CONCRETE® È UN MARCHIO REGISTRATO IN ESCLUSIVA SUL MERCATO DA BELLITALIA. ESSO NASCE DALLA COLLABORAZIONE DELL'AZIENDA CON I RICERCATORI DEL DIPARTIMENTO DI SCIENZE E INGEGNERIA DELLA MATERIA, DELL'AMBIENTE ED URBANISTICA DELL'UNIVERSITÀ POLITECNICA DELLE MARCHE, **SIMAU** E CON STUDI DI DESIGN DI FAMA INTERNAZIONALE.

MATERIALE CEMENTIZIO INNOVATIVO, REALIZZATO CON LE TECNOLOGIE PIÙ ALL'AVANGUARDIA, **UNTRATENSE CONCRETE**® È IL FUTURO.

ESTREMAMENTE DUTTILE E IN GRADO DI RAGGIUNGERE SPESSORI MOLTO SOTTILI, PUÒ ESSERE COLATO ANCHE NELLE FORME



PIÙ COMPLESSE, GRAZIE ALLA CAPACITÀ DI SCORRIMENTO E DI RIEMPIMENTO DEGLI INTERSTIZI PIÙ ANGUSTI.

UTC® È UN MATERIALE DALLE CARATTERISTICHE MECCANICHE ELEVATISSIME ANCHE SENZA UTILIZZO DI COMPLESSE ARMATURE INTERNE.

QUESTA PECULIARITÀ DÀ SPAZIO AD UN'AMPIA LIBERTÀ CREATIVA IN FASE DI MODELLAZIONE, PERMETTENDO DI GENERARE MANUFATTI CON SUPERFICI A SPESSORI SOTTILISSIMI, CURVATI TRIDIMENSIONALMENTE NELLO SPAZIO E IN GRADO DI SODDISFARE LE ESIGENZE DEI DESIGNER PIÙ INTRAPRENDENTI CON INTEGRAZIONI AMBIENTALI ANCHE MOLTO COMPLESSE.

QUESTE CARATTERISTICHE SONO STATE VALORIZZATE ATTRAVERSO UN DESIGN IN GRADO DI ENFATIZZARLE PER DARE FORMA A OGGETTI DI ARREDO URBANO FINO A PRIMA IMPENSABILI, CHE TRASFORMERANNO IL MODO DI ABITARE E DI VIVERE GLI SPAZI PUBBLICI DELLE CITTÀ.

L'AGGIUNTA DI PIGMENTI CHE IN FASE DI MISCELAZIONE DIVENTANO PARTE INTRINSECA DEL MATERIALE ASSICURA UNA LUNGA RESISTENZA DELLE COLORAZIONI FINALI.

UTC® MANTIENE INOLTRE UN GRADO DI RICICLO INFINITO, GRAZIE ALLA NATURA DI BASE FORMATA DA CEMENTI E INERTI DI PRIMISSIMA QUALITÀ OTTENUTI DA CAVE CERTIFICATE E DA PROCESSI CONTROLLATI.





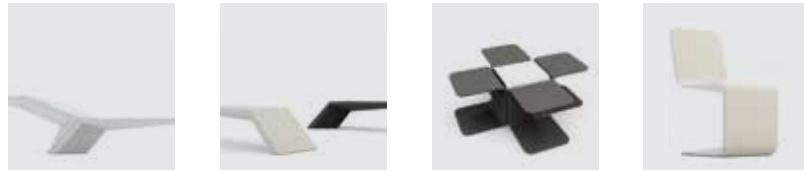

Jonathan
p. 64

Wing
p. 72

Spring
p. 78

Roger
p. 84

Alba
p. 90

Aurora
p. 96

Bridge
p. 100

Bridge Curva
p. 106

Thin
p. 112

Hamlet
p. 116

Frank
p. 122

Bubble
p. 126

**Solar
Solar Square**
p. 132

Circle
p. 138

BENCHES / PANCHINE

PLANTERS / FIORIERE

LITTER BINS / CESTINI

TREE GRIDS / GRIGLIE PER ALBERI



JONATHAN / DEL PONTE, ZAMBELLI

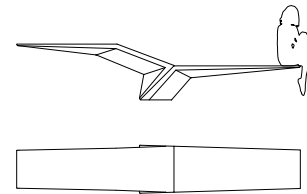

L: 3751 mm
W: 634 mm
H: 738 mm
W: 667 kg

MATERIALS: ULTRATENSE CONCRETE IN WHITE OR CHARCOAL GRAY, WITH PROTECTIVE COATING SHINY OR OPAQUE.

FINISHING: NATURAL SMOOTH.

MATERIALI: ULTRATENSE CONCRETE ANTRACITE O BIANCO, CON TRATTAMENTO PROTETTIVO LUCIDO O SATINATO.

FINITURA: LISCIO NATURALE.

ULTRATENSE CONCRETE® /
L'ULTRALEGGERO





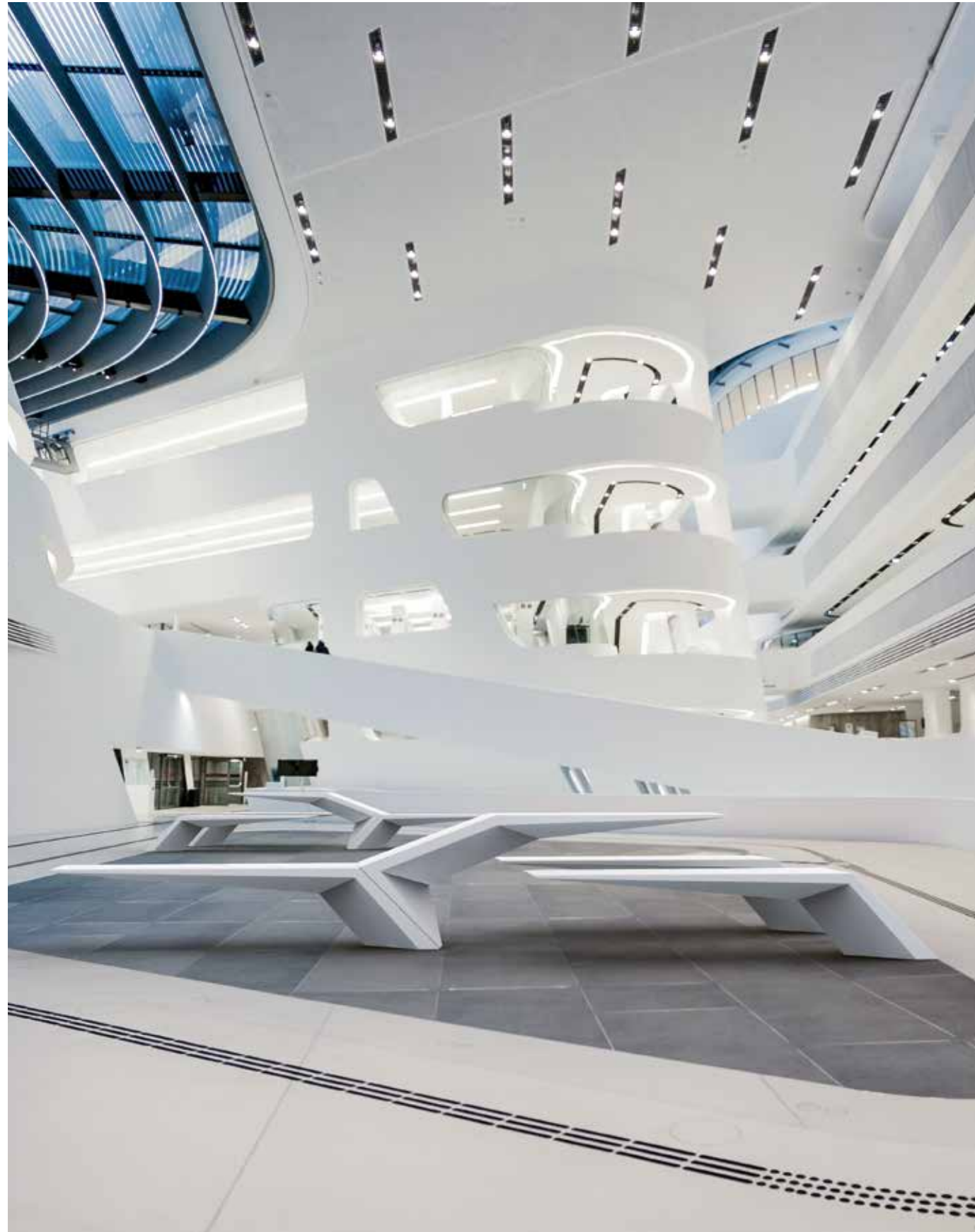





WING / DEL PONTE, ZAMBELLI

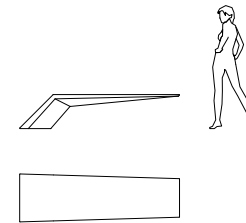

L: 2114 mm
W: 634 mm
H: 450 mm
W: 309 kg

MATERIALS: ULTRATENSE CONCRETE IN WHITE OR CHARCOAL GRAY, WITH PROTECTIVE COATING SHINY OR OPAQUE.

FINISHING: NATURAL SMOOTH.

MATERIALI: ULTRATENSE CONCRETE ANTRACITE O BIANCO, CON TRATTAMENTO PROTETTIVO LUCIDO O SATINATO.

FINITURA: LISCIO NATURALE.

ULTRATENSE CONCRETE® /
L'ULTRALEGGERO





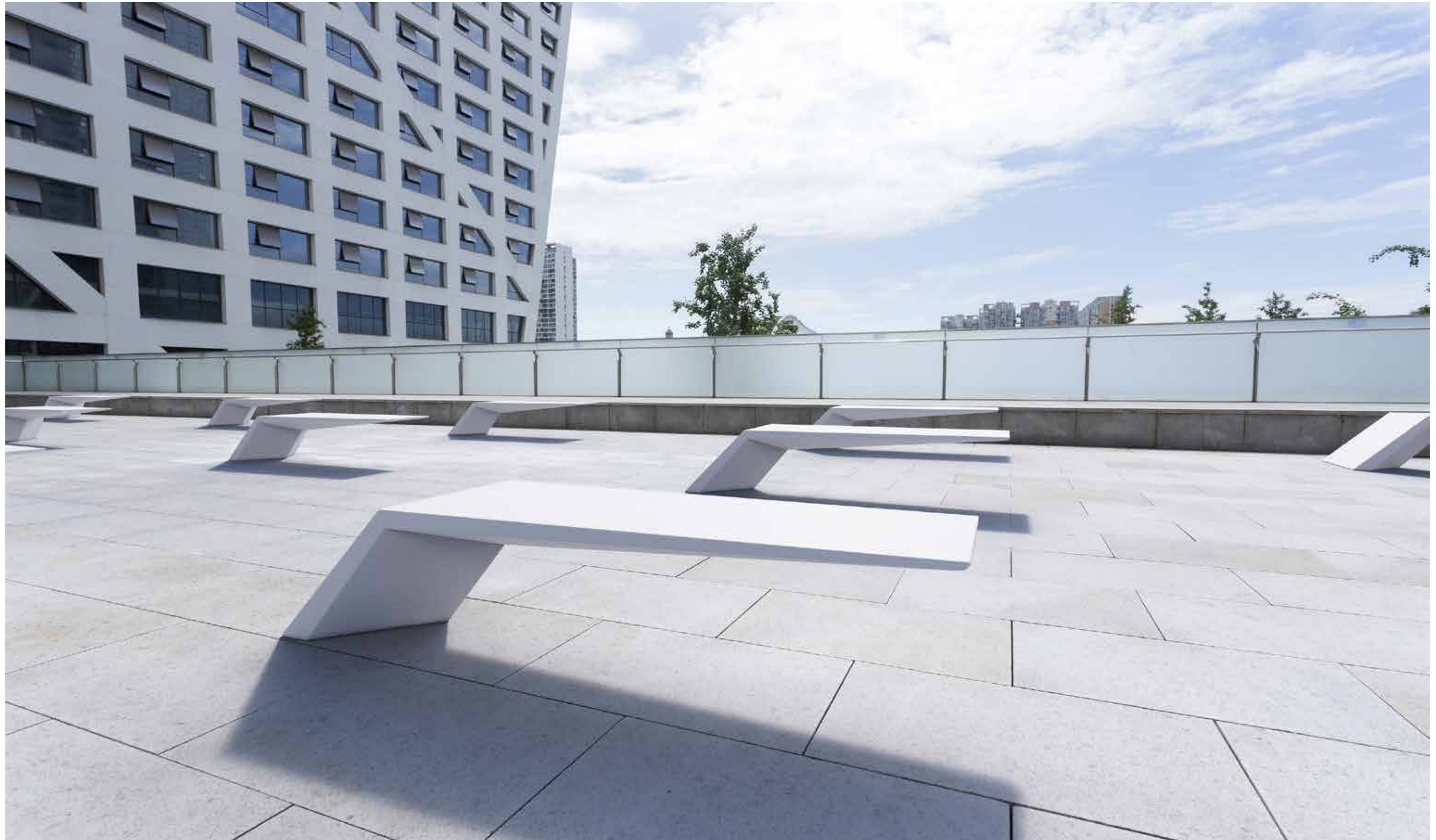

SPRING / DEL PONTE, ZAMBELLI

MATERIALS: ULTRATENSE CONCRETE IN WHITE OR CHARCOAL GRAY, WITH PROTECTIVE COATING SHINY OR OPAQUE.

FINISHING: NATURAL SMOOTH.

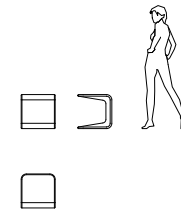

L: 449 mm
W: 450 mm
H: 450 mm
W: 54 kg

MATERIALI: ULTRATENSE CONCRETE ANTRACITE O BIANCO, CON TRATTAMENTO PROTETTIVO LUCIDO O SATINATO.

FINITURA: LISCIO NATURALE.

ULTRATENSE CONCRETE® /
L'ULTRALEGGERO







ROGER /

DEL PONTE, ZAMBELLI

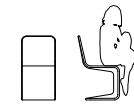

L: 449 mm
W: 450 mm
H: 847 mm
W: 65 kg

MATERIALS: ULTRATENSE CONCRETE IN WHITE OR CHARCOAL GRAY, WITH PROTECTIVE COATING SHINY OR OPAQUE.

FINISHING: NATURAL SMOOTH.

MATERIALI: ULTRATENSE CONCRETE ANTRACITE O BIANCO, CON TRATTAMENTO PROTETTIVO LUCIDO O SATINATO.

FINITURA: LISCIO NATURALE.



ULTRATENSE CONCRETE® /
L'ULTRALEGGERO







ALBA /

BELLITALIA® DESIGN DEPARTMENT

MATERIALS: ULTRATENSE CONCRETE IN WHITE OR CHARCOAL GRAY, WITH PROTECTIVE COATING SHINY OR OPAQUE.

FINISHING: NATURAL SMOOTH.

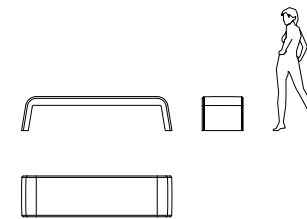

L: 1990 mm
W: 540 mm
H: 450 mm
W: 230 kg

MATERIALI: ULTRATENSE CONCRETE ANTRACITE O BIANCO, CON TRATTAMENTO PROTETTIVO LUCIDO O SATINATO.

FINITURA: LISCIO NATURALE.

ULTRATENSE CONCRETE® /
L'ULTRALEGGERO

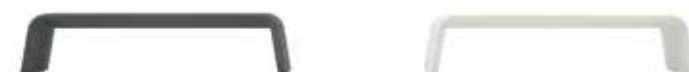





AURORA /

BELLITALIA® DESIGN DEPARTMENT

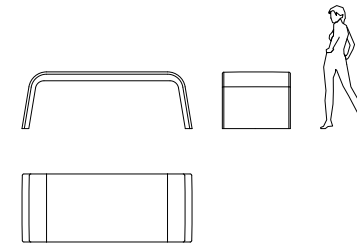

L: 2250 mm
W: 900 mm
H: 750 mm
W: 479 kg

MATERIALS: ULTRATENSE CONCRETE IN WHITE OR CHARCOAL GRAY, WITH PROTECTIVE COATING SHINY OR OPAQUE.

FINISHING: NATURAL SMOOTH.

MATERIALI: ULTRATENSE CONCRETE ANTRACITE O BIANCO, CON TRATTAMENTO PROTETTIVO LUCIDO O SATINATO.

FINITURA: LISCIO NATURALE.

ULTRATENSE CONCRETE® /
L'ULTRALEGGERO



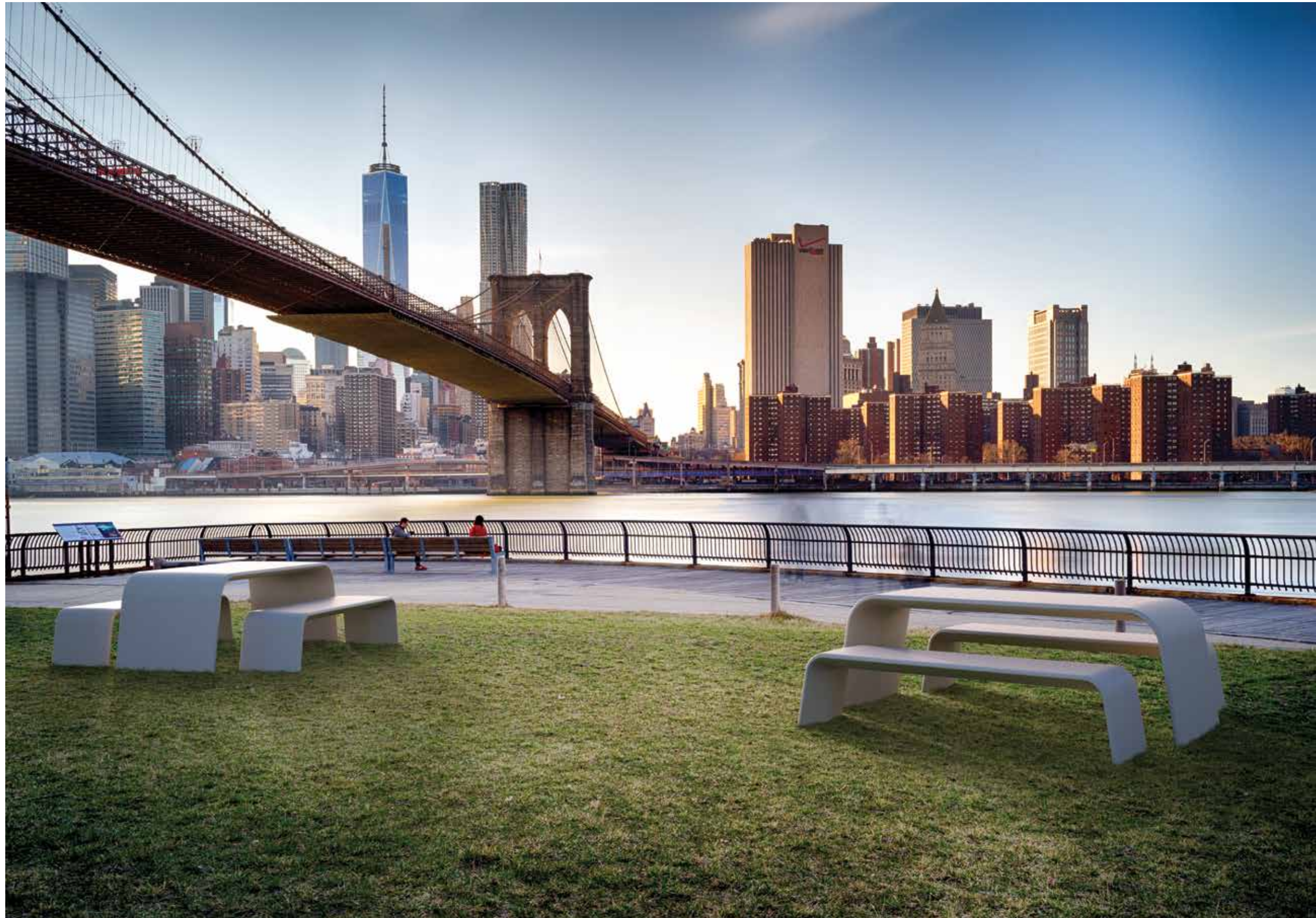

BRIDGE / C+S ARCHITECTS

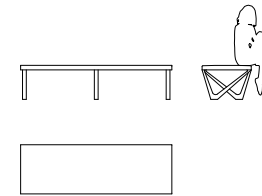

L: 2000 mm
W: 650 mm
H: 450 mm
W: 250 kg

MATERIALS: ULTRATENSE CONCRETE IN WHITE OR CHARCOAL GRAY, WITH PROTECTIVE COATING SHINY OR OPAQUE.
FINISHING: NATURAL SMOOTH.

MATERIALI: ULTRATENSE CONCRETE ANTRACITE O BIANCO, CON TRATTAMENTO PROTETTIVO LUCIDO O SATINATO.
FINITURA: LISCIO NATURALE.



ULTRATENSE CONCRETE® /
L'ULTRALEGGERO





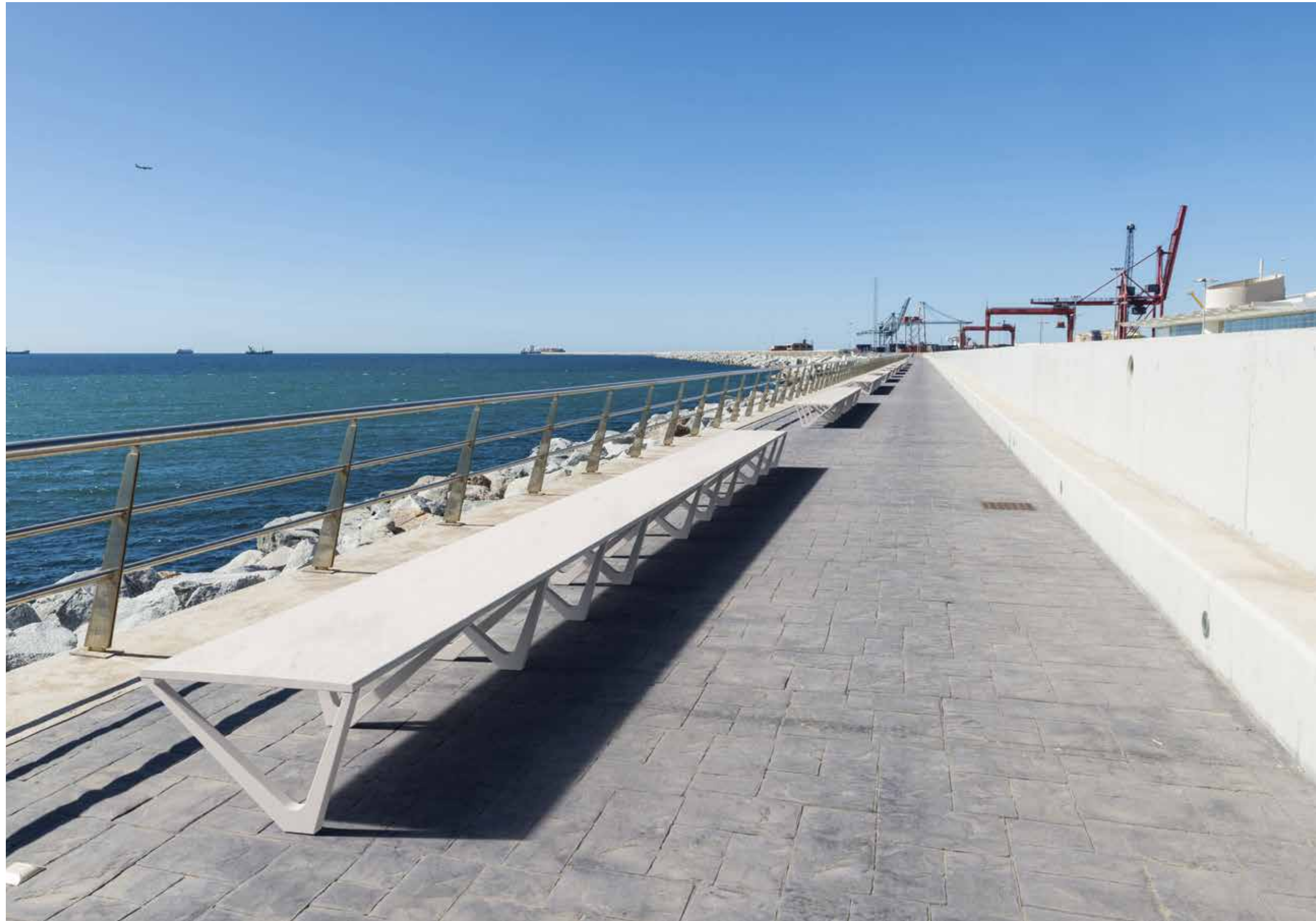

BRIDGE CURVA /

C+S ARCHITECTS

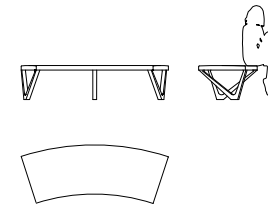

L: 1947 mm
W: 774 mm
H: 450 mm
W: 179 kg

MATERIALS: ULTRATENSE CONCRETE IN WHITE OR CHARCOAL GRAY, WITH PROTECTIVE COATING SHINY OR OPAQUE.

FINISHING: NATURAL SMOOTH.

MATERIALI: ULTRATENSE CONCRETE ANTRACITE O BIANCO, CON TRATTAMENTO PROTETTIVO LUCIDO O SATINATO.

FINITURA: LISCIO NATURALE.



ULTRATENSE CONCRETE® /
L'ULTRALEGGERO





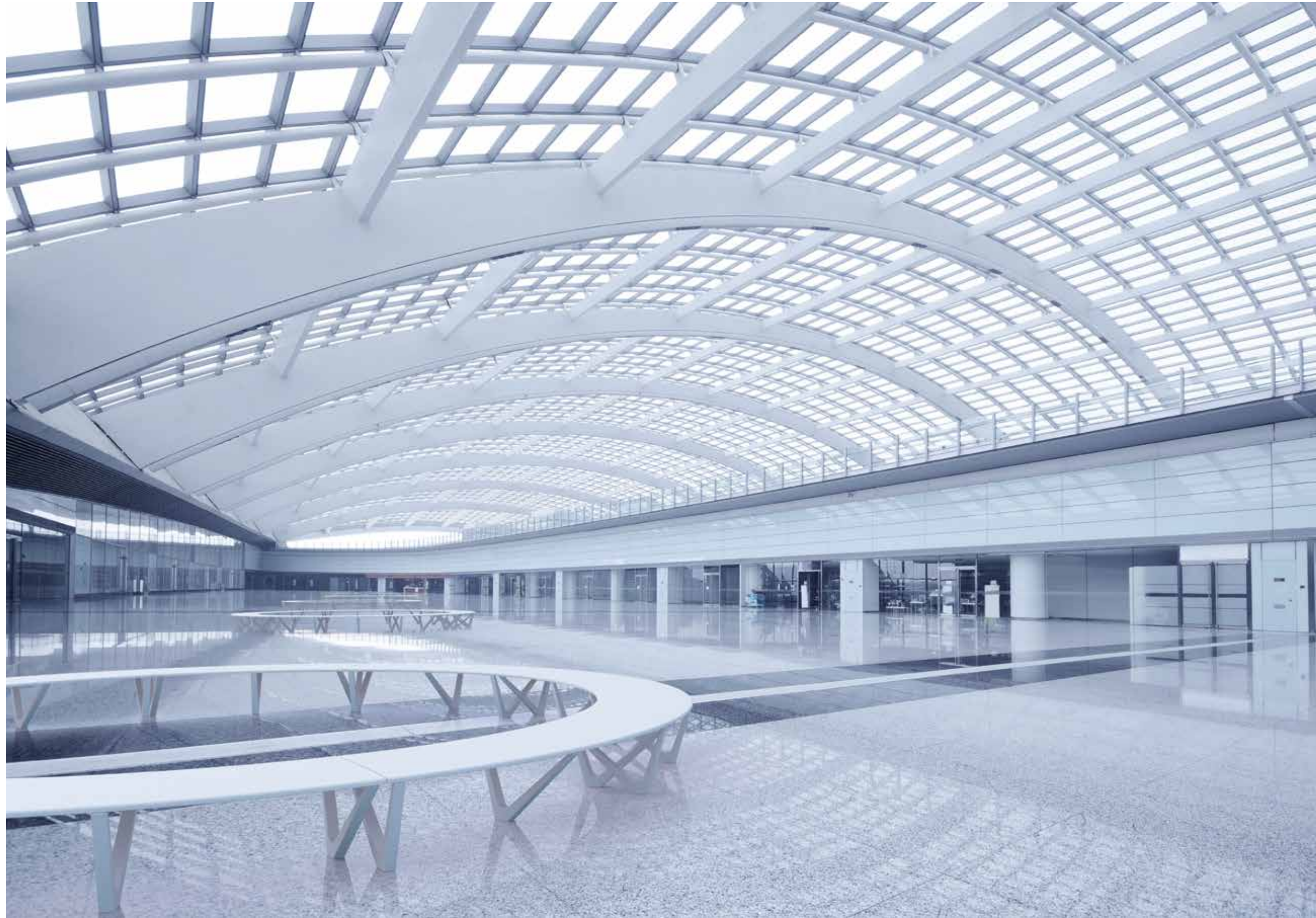

THIN /

C+S ARCHITECTS

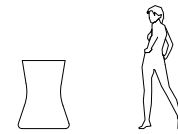

Ø: 667 mm
H: 900 mm
W: 279 kg

MATERIALS: ULTRATENSE CONCRETE IN WHITE OR CHARCOAL GRAY, WITH PROTECTIVE COATING SHINY OR OPAQUE.

FINISHING: NATURAL SMOOTH.

MATERIALI: ULTRATENSE CONCRETE ANTRACITE O BIANCO, CON TRATTAMENTO PROTETTIVO LUCIDO O SATINATO.

FINITURA: LISCIO NATURALE.

ULTRATENSE CONCRETE® /
L'ULTRALEGGERO





HAMLET /

C+S ARCHITECTS

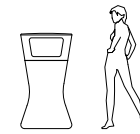

Ø: 677mm
H: 1259 mm
W: 354 Kg

MATERIALS: ULTRATENSE CONCRETE IN WHITE OR CHARCOAL GRAY, WITH PROTECTIVE COATING SHINY OR OPAQUE.

FINISHING: NATURAL SMOOTH.

MATERIALI: ULTRATENSE CONCRETE ANTRACITE O BIANCO, CON TRATTAMENTO PROTETTIVO LUCIDO O SATINATO.

FINITURA: LISCIO NATURALE.

ULTRATENSE CONCRETE® /
L'ULTRALEGGERO









FRANK / GROOVE DESIGN



L: 550 mm
W: 550 mm
H: 969 mm
W: 224 Kg

MATERIALS: ULTRATENSE CONCRETE IN WHITE OR CHARCOAL GRAY, WITH PROTECTIVE COATING SHINY OR OPAQUE.

FINISHING: NATURAL SMOOTH.

MATERIALI: ULTRATENSE CONCRETE ANTRACITE O BIANCO, CON TRATTAMENTO PROTETTIVO LUCIDO O SATINATO.

FINITURA: LISCIO NATURALE.

ULTRATENSE CONCRETE® / L'ULTRALEGGERO







BUBBLE /

BELLITALIA® DESIGN DEPARTMENT

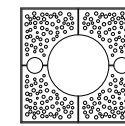
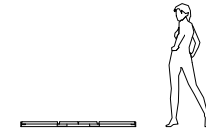

L: 1520 mm
W: 1520 mm
H: 64 mm
W: 139 Kg

MATERIALS: ULTRATENSE CONCRETE IN WHITE OR CHARCOAL GRAY, WITH PROTECTIVE COATING SHINY OR OPAQUE.

FINISHING: NATURAL SMOOTH.

MATERIALI: ULTRATENSE CONCRETE ANTRACITE O BIANCO, CON TRATTAMENTO PROTETTIVO LUCIDO O SATINATO.

FINITURA: LISCIO NATURALE.

ULTRATENSE CONCRETE® /
L'ULTRALEGGERO

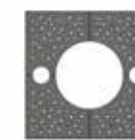
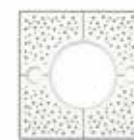



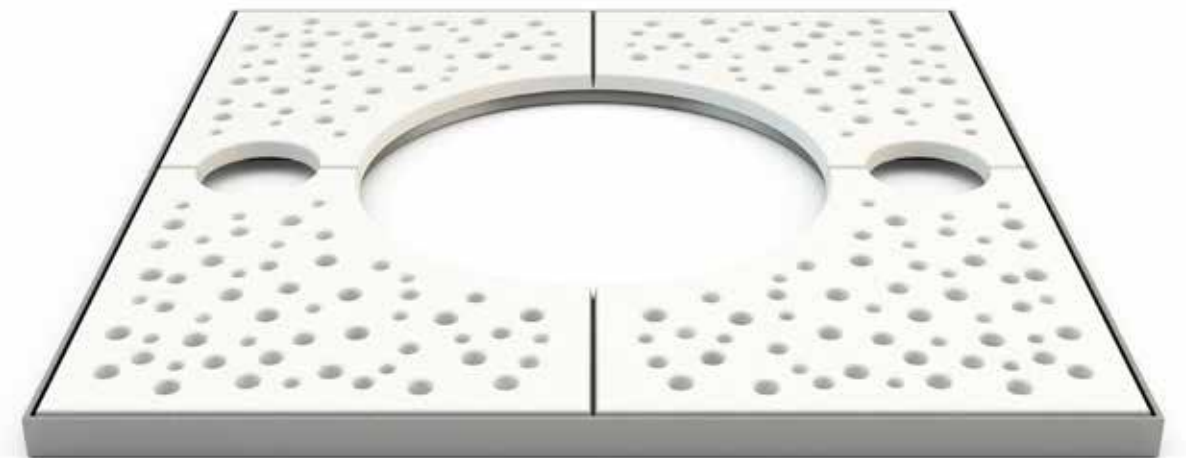

SOLAR /
C+S ARCHITECTS



MATERIALS: ULTRATENSE CONCRETE IN WHITE OR CHARCOAL GRAY, WITH PROTECTIVE COATING SHINY OR OPAQUE.

FINISHING: NATURAL SMOOTH.

MATERIALI: ULTRATENSE CONCRETE ANTRACITE O BIANCO, CON TRATTAMENTO PROTETTIVO LUCIDO O SATINATO.

FINITURA: LISCIO NATURALE.



SOLAR
Ø: 1447 mm
Ø: 407 mm
H: 40 mm
W: 93 Kg

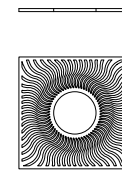

SOLAR SQUARE
W: 1480 mm
Ø: 560 mm
H: 40 mm
W: 123 Kg

ULTRATENSE CONCRETE® /
L'ULTRALEGGERO







CIRCLE /

C+S ARCHITECTS

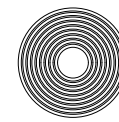
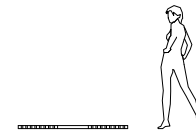

Ø: 1480 mm
 Ø: 560 mm
 H: 40 mm
 W: 102 Kg

MATERIALS: ULTRATENSE CONCRETE IN WHITE OR CHARCOAL GRAY, WITH PROTECTIVE COATING SHINY OR OPAQUE.

FINISHING: NATURAL SMOOTH.

MATERIALI: ULTRATENSE CONCRETE ANTRACITE O BIANCO, CON TRATTAMENTO PROTETTIVO LUCIDO O SATINATO.

FINITURA: LISCIO NATURALE.

ULTRATENSE CONCRETE® /
 L'ULTRALEGGERO







PRECIOUS STONES /
PIETRE PREZIOSE

PRECIOUS STONES / PIETRE PREZIOSE

THE CONGLOMERATES MADE FROM **BELLITALIA**® MATERIALS ARE PLIABLE: IT IS POSSIBLE TO CREATE ALMOST ANY SHAPE AND ARCHITECTURAL OBJECT; ARCHITECTS AND DESIGNERS CAN ADOPT THEM TO GIVE RISE TO THEIR PERSONAL STYLE AND TO FULLY EXPRESS THEIR CREATIVITY.

THEY ARE MADE WITH THE USE OF WATER, SAND, GRAVEL AND CEMENT, ALL MATERIALS THAT ARE, OR ARE DERIVED FROM, NATURAL RAW MATERIALS. THE USE OF CONCRETE PRODUCTS AND AGGREGATES OF NATURAL MARBLE STONES CAN SIGNIFICANTLY REDUCE MAINTENANCE COSTS AS THESE MATERIALS ARE LONG LASTING AND DURABLE, WITH CHANGES THAT ARE ALMOST NON-EXISTENT OVER TIME.



IL CONGLOMERATI REALIZZATI DA **BELLITALIA®** SONO MATERIALI PLASMABILI: È POSSIBILE INFATTI REALIZZARE PRESSOCHÉ QUALSIASI FORMA E OGGETTO ARCHITETTONICO; GLI ARCHITETTI E I DESIGNERS POSSONO ADOTTARLI PER DARE ORIGINE A UN PROPRIO STILE PERSONALE E PER ESPRIMERE APPIENO LA PROPRIA CREATIVITÀ.

ESSI SONO REALIZZATI CON L'IMPIEGO DI ACQUA, SABBIA, GHIAIA E CEMENTO, TUTTI MATERIALI CHE SONO O DERIVANO DA MATERIE PRIME NATURALI. L'UTILIZZO DI PRODOTTI IN CALCESTRUZZO E AGGREGATO DI PIETRE DI MARMO NATURALI PERMETTE DI ABBATTERE NOTEVOLMENTE I COSTI DI MANUTENZIONE POICHÉ QUESTI MATERIALI SONO DURATURI E RESISTENTI, CON ALTERAZIONI NEL TEMPO PRESSOCHÉ NULLE.

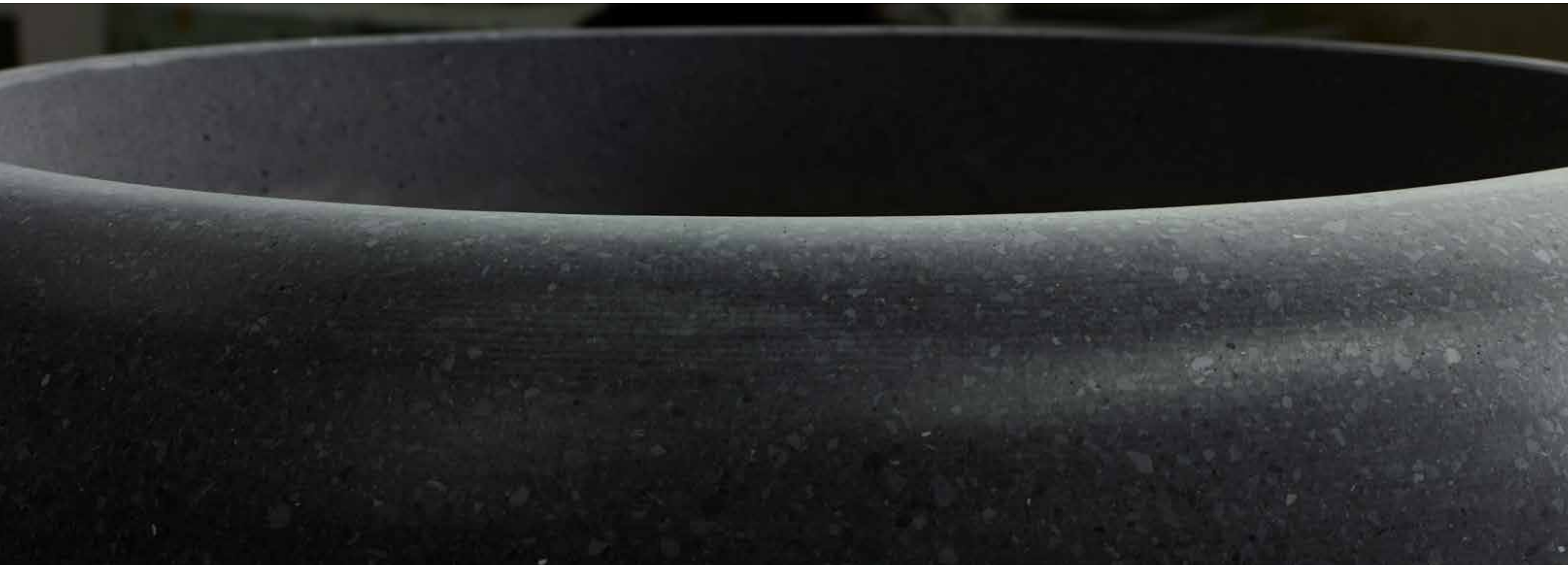

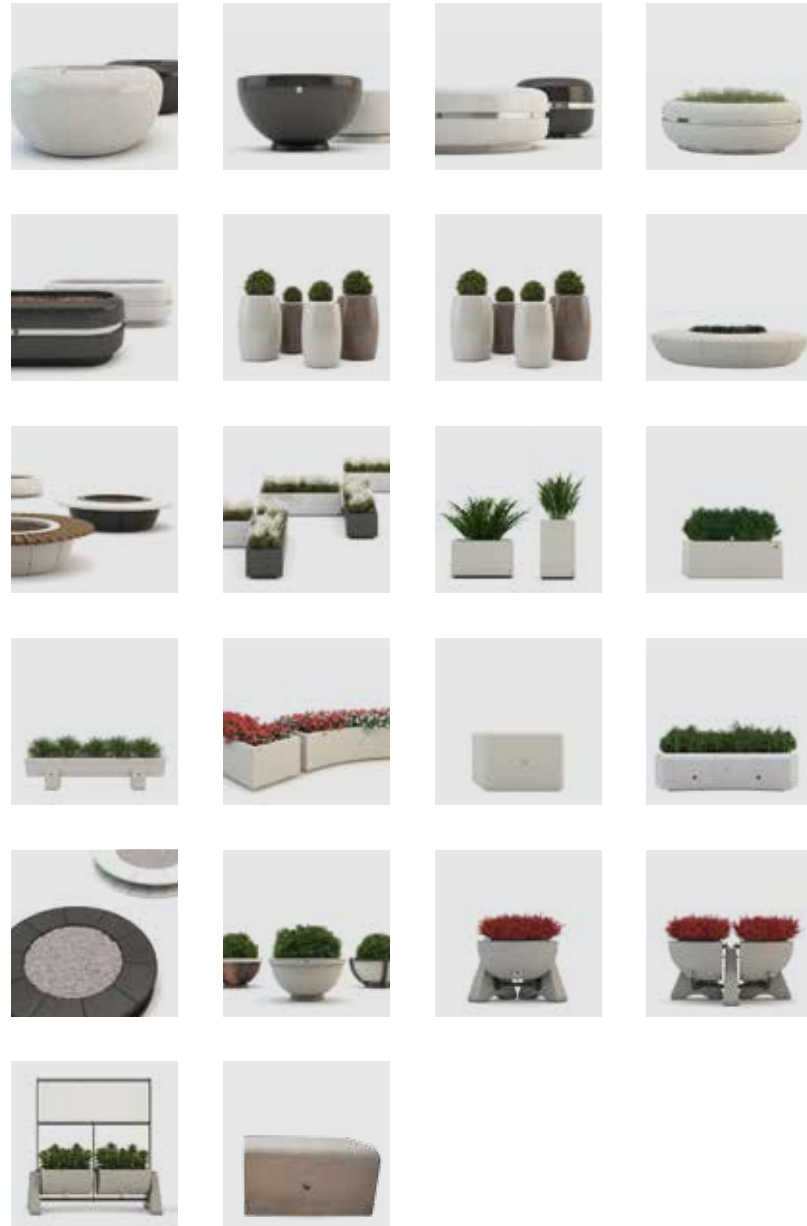

<p>Pianeti Luna - Venere Giove -Marte p. 150</p>	<p>Primavera Estate p. 166</p>	<p>Timeless 860 -1220 1620 - 2020 p. 174</p>	<p>Pawn p. 182</p>
<p>Cristina α- β p. 184</p>	<p>Pegaso p. 194</p>	<p>Orione p. 194</p>	<p>Olimpo p. 200</p>
<p>Ring Ring Reverse p. 208</p>	<p>Artemide Dritta - Curva p.214</p>	<p>Luonge Low - Tall p. 220</p>	<p>Pair Short - Long p. 224</p>
<p>Menhir p. 228</p>	<p>Kubb Mono Double Curved p. 232</p>	<p>Berry p. 238</p>	<p>Onda Onda Curva p. 240</p>
<p>Corolla p. 246</p>	<p>Mug p. 252</p>	<p>A - Swing p. 256</p>	<p>B - Swing p. 256</p>
<p>C - Swing p. 258</p>	<p>Cassiopea p. 262</p>		

PLANTERS / FIORIERE

I PIANETI /

BELLITALIA® DESIGN DEPARTMENT

MATERIALS: RECONSTITUTED NATURAL MARBLE STONES OR WHITE GRANITE.
FINISHING: POLISHED OR BUSH HAMMERED.

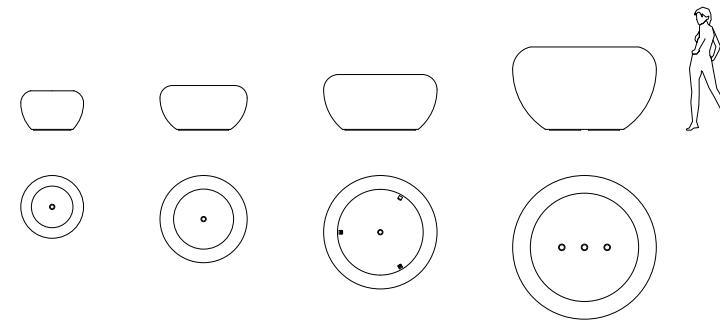

LUNA
 Ø 830 mm
 H 520 mm
 W 360 kg

VENERE
 Ø 1153 mm
 H 590 mm
 W 800 kg

GIOVE
 Ø 1500 mm
 H 735 mm
 W 1500 kg

MARTE
 Ø 1900 mm
 H 1100 mm
 W 3005 kg

PRECIOUS STONES /
 PIETRE PREZIOSE



WHITE GRANITE /
 GRANITO BIANCO



MATERIALI: DISPONIBILE IN AGGREGATO DI PIETRE DI MARMO NATURALI O IN GRANITO BIANCO.
FINITURA: LEVIGATURA O BOCCIARDATURA.





MARTE PLANTERS /
FIORIERE MARTE





GIOVE PLANTERS /
FIORIERE GIOVE



VENERE PLANTERS /
FIORIERE VENERE

opposite page /
pagina a fronte

LUNA PLANTERS /
FIORIERE LUNA



VENERE PLANTERS /
FIORIERE VENERE



opposite page /
pagina a fronte
GIOVE PLANTERS /
FIORIERE GIOVE





VENERE PLANTERS /
FIORIERE VENERE

opposite page /
pagina a fronte
VENERE PLANTERS /
FIORIERE VENERE





MARTE PLANTERS /
FIORIERE MARTE

PRIMAVERA - ESTATE /

BELLITALIA® DESIGN DEPARTMENT

MATERIALS: RECONSTITUTED NATURAL MARBLE STONES OR WHITE GRANITE.

FINISHING: POLISHED OR BUSH HAMMERED. PROVIDED WITH LEVELLING SYSTEM.

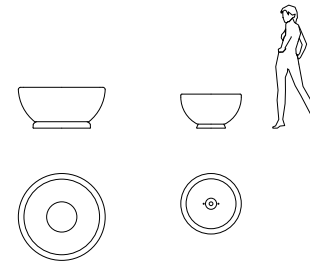

ESTATE
 Ø 1150 mm
 H 540 mm
 W 594 mm

PRIMAVERA
 Ø 800 mm
 H 450 mm
 W 135 kg

MATERIALI: DISPONIBILE IN AGGREGATO DI PIETRE DI MARMO NATURALI O IN GRANITO BIANCO.

FINITURA: LEVIGATURA O BOCCIARDATURA. CON LIVELLAMENTO.



PRECIOUS STONES /
 PIETRE PREZIOSE



WHITE GRANITE /
 GRANITO BIANCO



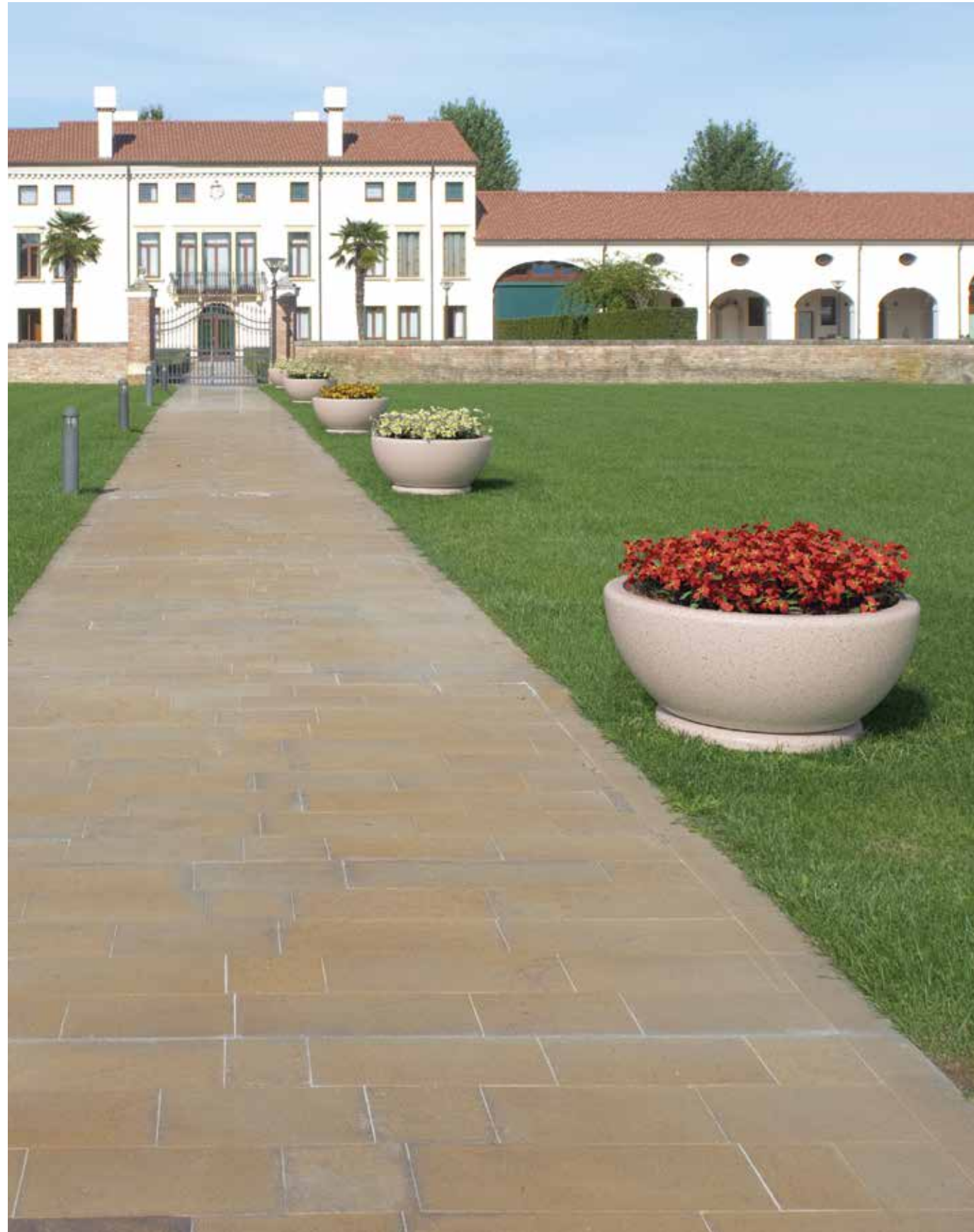





TIMELESS /

BELLITALIA® DESIGN DEPARTMENT

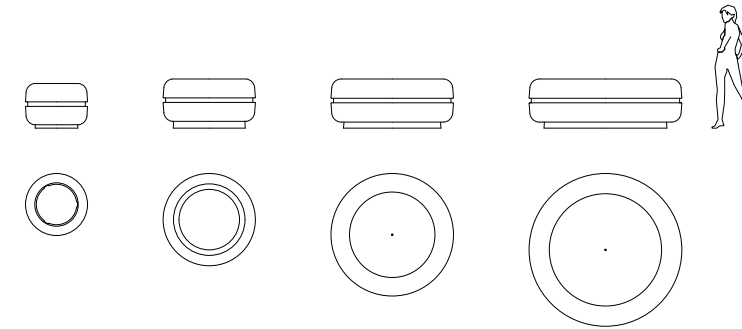

820 Ø 820 mm H 590 mm W 408 kg	1220 Ø 1220 mm H 650 mm W 910 kg	1620 Ø 1620 mm H 650 mm W 1468 kg	2020 Ø 2020 mm H 650 mm W 2114 kg
--	--	---	---

MATERIALS: RECONSTITUTED NATURAL MARBLE STONES, WHITE GRANITE OR GREY CONCRETE.

FINISHING: POLISHED, BUSH HAMMERED OR SANDBLASTED.

ACCESSORIES: COPPER OR STAINLESS STEEL BAND. PROVIDED WITH LEVELLING SYSTEM.

MATERIALI: DISPONIBILE IN AGGREGATO DI PIETRE DI MARMO NATURALI, GRANITO BIANCO O CEMENTO GRIGIO.

FINITURA: LEVIGATURA, BOCCIARDATURA O SABBIATURA.

ACCESSORI: FASCIA IN RAME O FASCIA IN INOX. CON LIVELLAMENTO.



PRECIOUS STONES /
PIETRE PREZIOSE



WHITE GRANITE /
GRANITO BIANCO



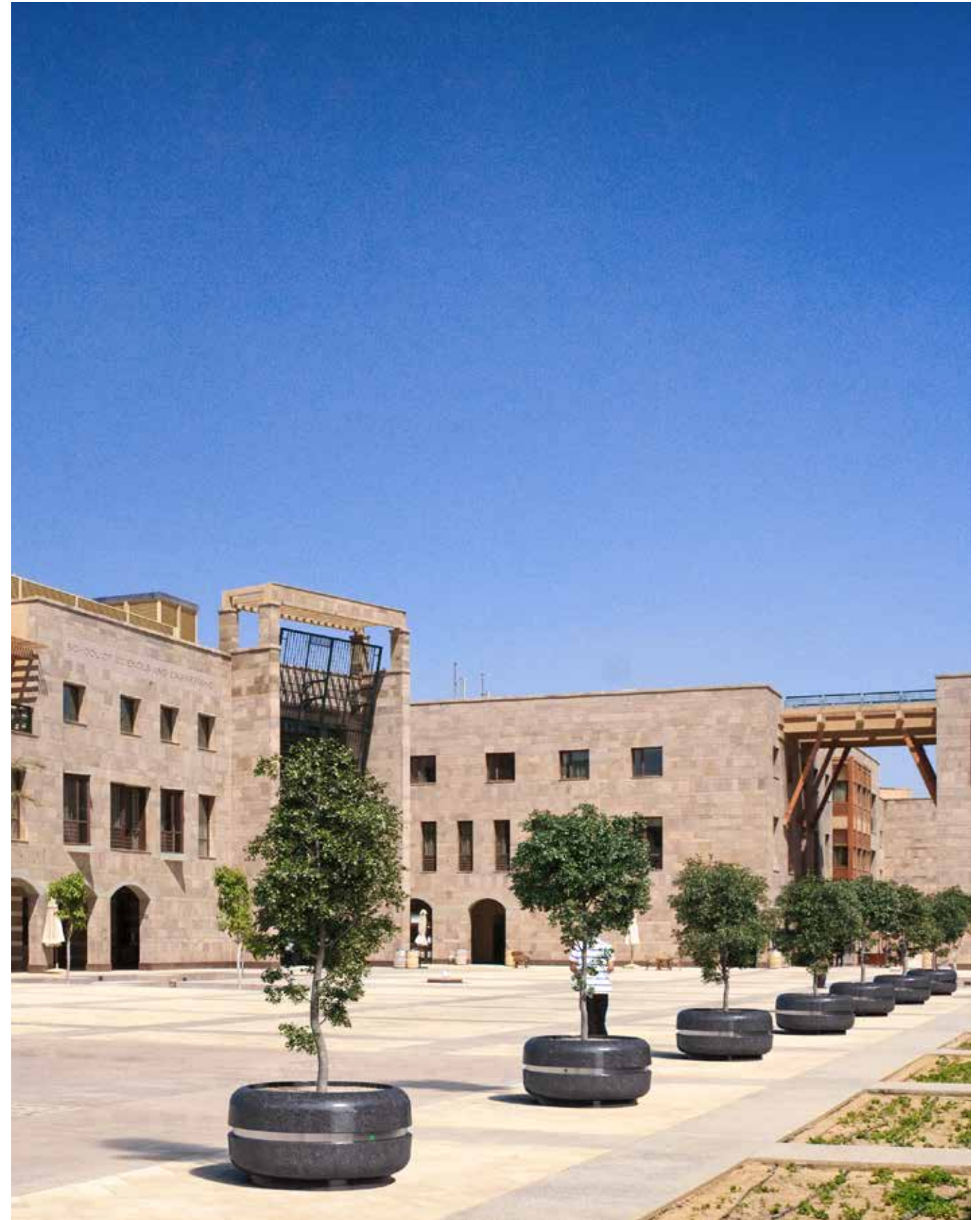







PAWN /

BELLITALIA® DESIGN DEPARTMENT

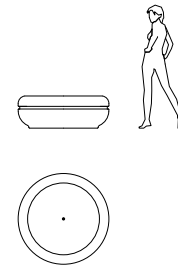

Ø 1200 mm
H 425 mm
W 408 kg

MATERIALS: RECONSTITUTED NATURAL MARBLE STONES OR WHITE GRANITE.

FINISHING: SANDBLASTED, POLISHED OR BUSH HAMMERED.

ACCESSORIES: COPPER OR STAINLESS STEEL BAND.

MATERIALI: DISPONIBILE IN AGGREGATO DI PIETRE DI MARMO NATURALI O IN GRANITO BIANCO.

FINITURA: SABBIATURA, LEVIGATURA O BOCCIARDATURA.

ACCESSORI: FASCIA IN RAME O FASCIA IN INOX.

PRECIOUS STONES /
PIETRE PREZIOSE



WHITE GRANITE /
GRANITO BIANCO



CRISTINA β - α / BELLITALIA® DESIGN DEPARTMENT

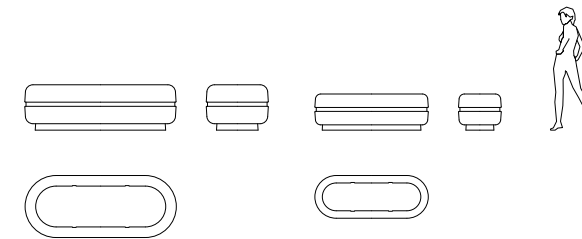

BETA
L 2000 mm
W 820 mm
H 600 mm
W 880 kg

ALPHA
L 1500 mm
W 565 mm
H 478 mm
W 350 kg

MATERIALS: RECONSTITUTED NATURAL MARBLE STONES, WHITE GRANITE OR GREY CONCRETE.

FINISHING: SANDBLASTED, POLISHED OR BUSH HAMMERED.

ACCESSORIES: COPPER OR STAINLESS STEEL BAND. PROVIDED WITH LEVELLING SYSTEM.

MATERIALI: DISPONIBILE IN AGGREGATO DI PIETRE DI MARMO NATURALI, GRANITO BIANCO O CEMENTO GRIGIO.

FINITURA: SABBIATURA, LEVIGATURA O BOCCIARDATURA.

ACCESSORI: FASCIA IN RAME O FASCIA IN INOX. CON LIVELLAMENTO.



PRECIOUS STONES /
PIETRE PREZIOSE



WHITE GRANITE /
GRANITO BIANCO





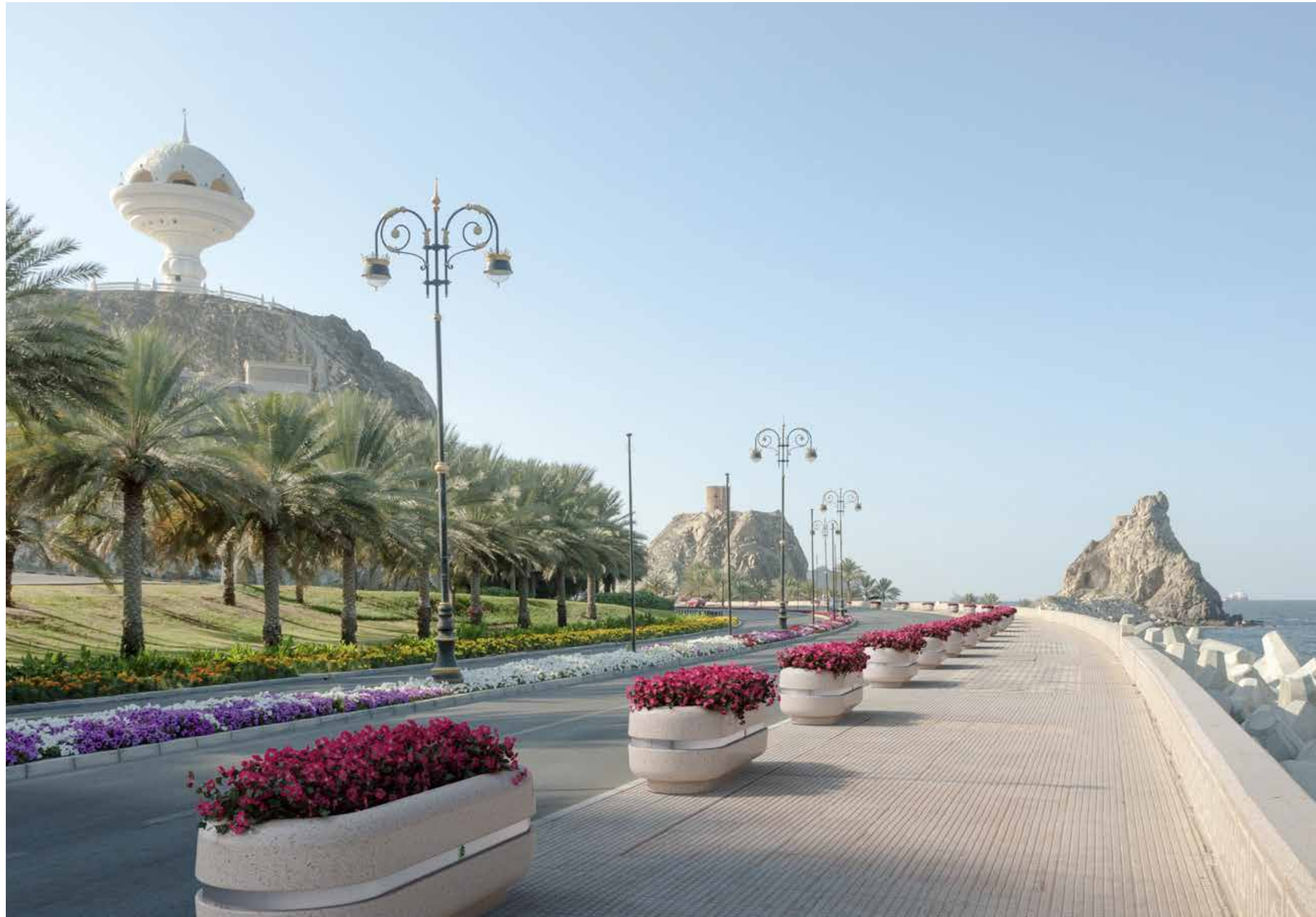





PEGASO - ORIONE /

BELLITALIA® DESIGN DEPARTMENT

MATERIALS: RECONSTITUTED NATURAL MARBLE STONES OR WHITE GRANITE.

FINISHING: POLISHED OR BUSH HAMMERED.

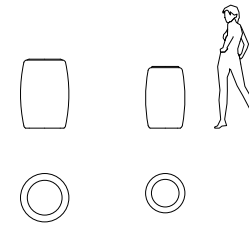

PEGASO	ORIONE
Ø 640 mm	Ø 520 mm
H 915 mm	H 816 mm
W 374 kg	W 242 kg

MATERIALI: DISPONIBILE IN AGGREGATO DI PIETRE DI MARMO NATURALI O IN GRANITO BIANCO.

FINITURA: LEVIGATURA O BOCCIARDATURA.

PRECIOUS STONES /
PIETRE PREZIOSE



WHITE GRANITE /
GRANITO BIANCO









OLIMPO /

BELLITALIA® DESIGN DEPARTMENT

MATERIALS: RECONSTITUTED NATURAL MARBLE STONES OR WHITE GRANITE.
FINISHING: POLISHED OR BUSH HAMMERED.

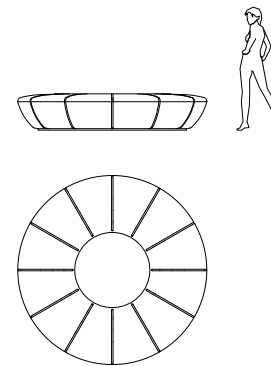

Ø 2500 mm
H 480 / 880 mm
W 3550 / 4515 kg

MATERIALI: DISPONIBILE IN AGGREGATO DI PIETRE DI MARMO NATURALI O IN GRANITO BIANCO.
FINITURA: LEVIGATURA O BOCCIARDATURA.

PRECIOUS STONES /
PIETRE PREZIOSE



WHITE GRANITE /
GRANITO BIANCO









RING-RING REVERSE /

BELLITALIA® DESIGN DEPARTMENT

MATERIALS: RECONSTITUTED NATURAL MARBLE STONES OR WHITE GRANITE.
FINISHING: POLISHED OR BUSH HAMMERED.
ACCESSORIES: WOODEN SLATS OR CONCRETE CIRCULAR SEAT.

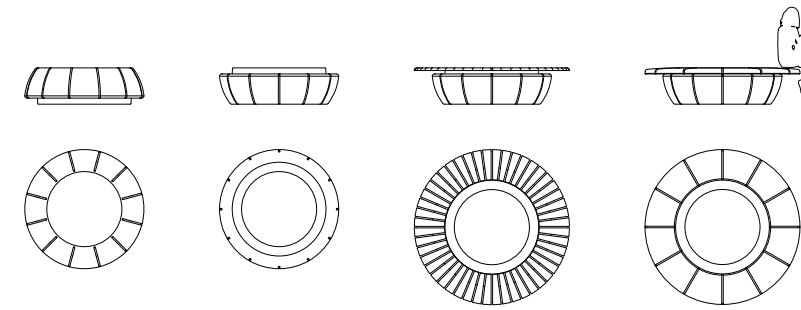

REVERSE
 Ø 1576 mm
 H 480 mm
 W 963 kg

RING
 Ø 1576/2052 mm
 H 480 mm
 W 963/1320 kg

MATERIALI: DISPONIBILE IN AGGREGATO DI PIETRE DI MARMO NATURALI O IN GRANITO BIANCO.
FINITURA: LEVIGATURA O BOCCIARDATURA.
ACCESSORI: SEDUTA CIRCOLARE IN LISTELLI DI LEGNO O IN CEMENTO.



PRECIOUS STONES /
 PIETRE PREZIOSE



WHITE GRANITE /
 GRANITO BIANCO



WOOD /
 LEGNO



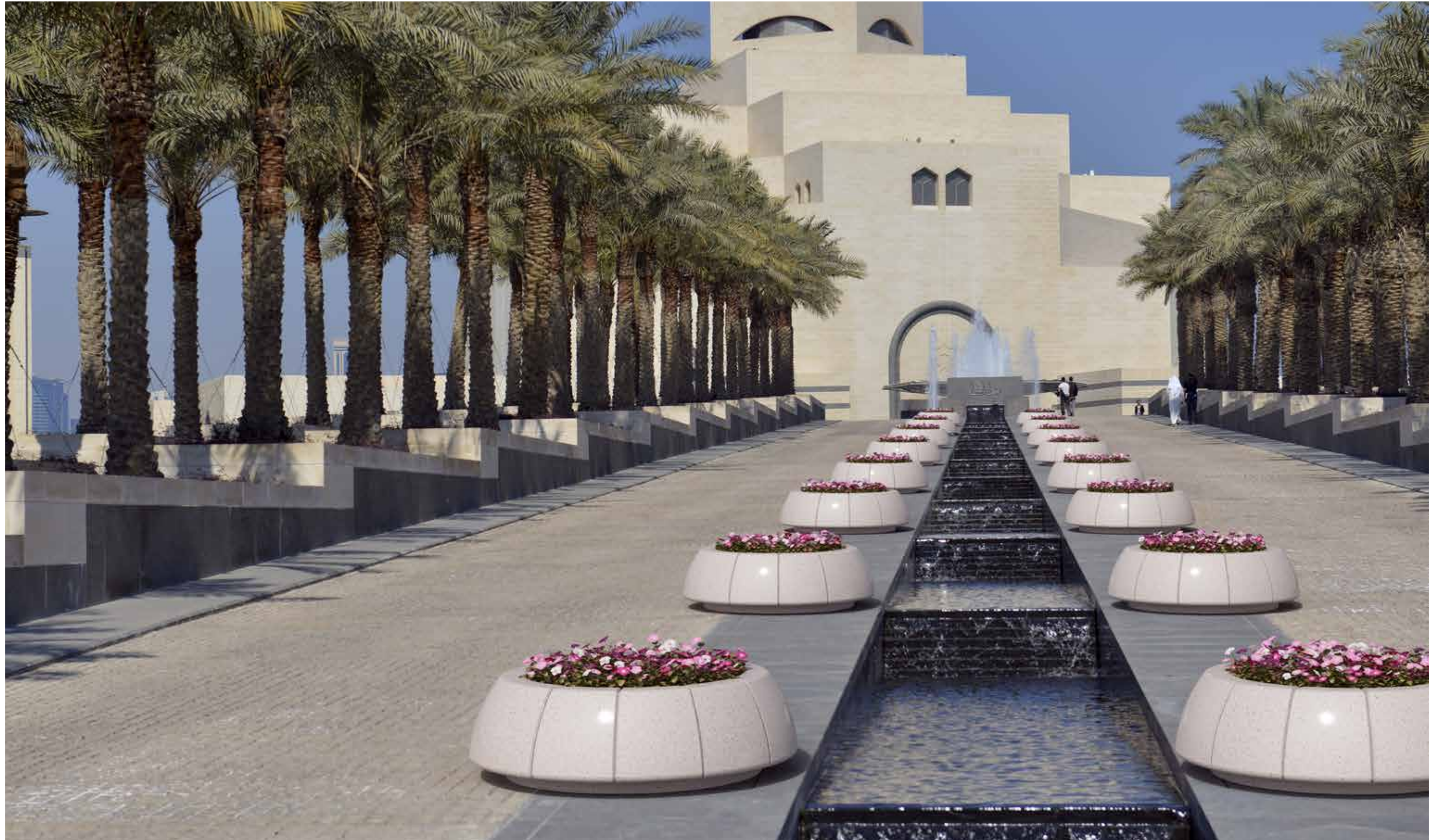



ARTEMIDE /

BELLITALIA® DESIGN DEPARTMENT

MATERIALS: RECONSTITUTED NATURAL MARBLE STONES OR WHITE GRANITE.

FINISHING: SANDBLASTED WITH POLISHED OR BUSH HAMMERED UPPER RIM. PROVIDED WITH LEVELLING SYSTEM.

MATERIALI: DISPONIBILE IN AGGREGATO DI PIETRE DI MARMO NATURALI O IN GRANITO BIANCO.

FINITURA: SABBIATURA, CON BORDO SUPERIORE LEVIGATO O BOCCIARDATO. CON LIVELLAMENTO.

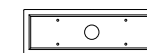
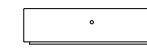

DRITTA

L 1800 mm
W 600 mm
H 470 mm
W 740 kg

CURVA

L 1907 mm
W 742 mm
H 480 mm
W 737 kg

PRECIOUS STONES /
PIETRE PREZIOSE



WHITE GRANITE /
GRANITO BIANCO









LOUNGE /

BELLITALIA® DESIGN DEPARTMENT

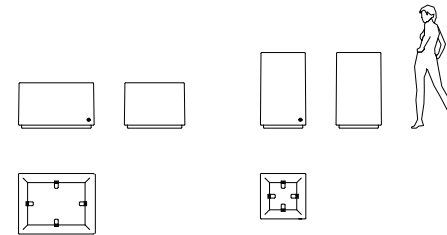

LOW
L 1000 mm
W 800 mm
H 600 mm
W 521 kg

TALL
L 600 mm
W 600 mm
H 1000 mm
W 477 kg

MATERIALS: RECONSTITUTED NATURAL MARBLE STONES OR WHITE GRANITE.

FINISHING: SANDBLASTED WITH POLISHED OR BUSH HAMMERED UPPER RIM. PROVIDED WITH LEVELLING SYSTEM.

MATERIALI: DISPONIBILE IN AGGREGATO DI PIETRE DI MARMO NATURALI O IN GRANITO BIANCO.

FINITURA: SABBIATURA, CON BORDO SUPERIORE LEVIGATO O BOCCIARDATO. CON LIVELLAMENTO.

PRECIOUS STONES /
PIETRE PREZIOSE



WHITE GRANITE /
GRANITO BIANCO





PAIR /

BELLITALIA® DESIGN DEPARTMENT

MATERIALS: RECONSTITUTED NATURAL MARBLE STONES OR WHITE GRANITE.
FINISHING: SANDBLASTED.

MATERIALI: DISPONIBILE IN AGGREGATO DI PIETRE DI MARMO NATURALI O IN GRANITO BIANCO.
FINITURA: SABBIATURA.

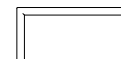
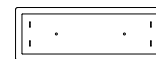

LONG
 L 1980 mm
 W 700 mm
 H 600 mm
 W 660 kg

SHORT
 L 1480 mm
 W 800 mm
 H 650 mm
 W 850 kg



PRECIOUS STONES /
 PIETRE PREZIOSE



WHITE GRANITE /
 GRANITO BIANCO







MENHIR /

BELLITALIA® DESIGN DEPARTMENT

MATERIALS: RECONSTITUTED NATURAL MARBLE STONES, WHITE GRANITE OR GREY CONCRETE.

FINISHING: SANDBLASTED.

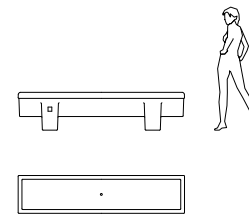

L 2200 mm
W 500 mm
H 500 mm
W 380 kg

MATERIALI: DISPONIBILE IN AGGREGATO DI PIETRE DI MARMO NATURALI, GRANITO BIANCO O CEMENTO GRIGIO.
FINITURA: SABBIATURA.

PRECIOUS STONES /
PIETRE PREZIOSE



WHITE GRANITE /
GRANITO BIANCO



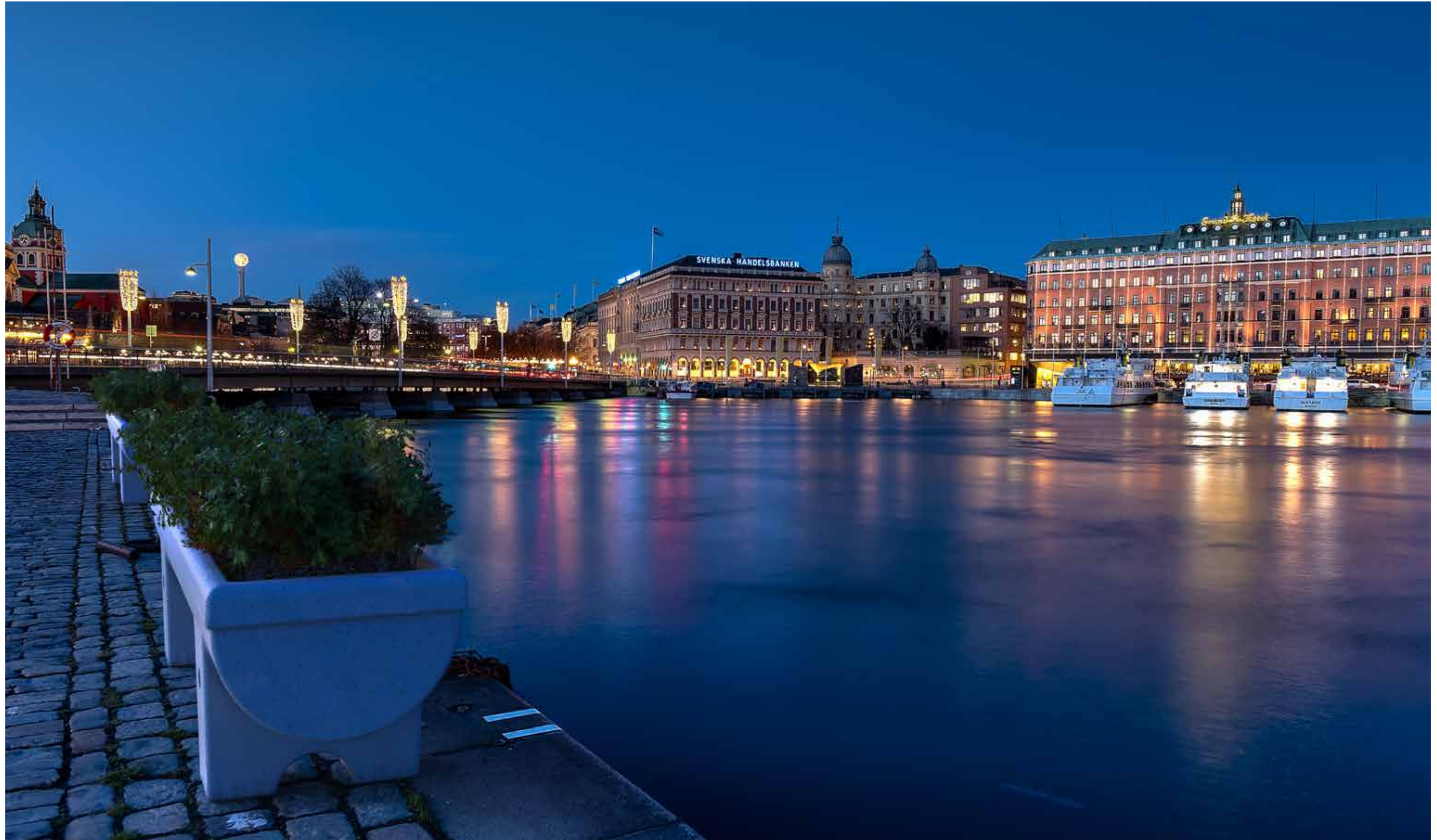

KUBB /

BELLITALIA® DESIGN DEPARTMENT

MATERIALS: RECONSTITUTED NATURAL MARBLE STONES OR WHITE GRANITE.
FINISHING: SANDBLASTED WITH POLISHED OR BUSH HAMMERED UPPER RIM.

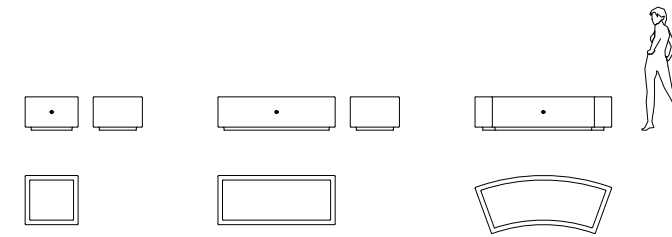

MONO
 L 700 mm
 W 650 mm
 H 440 mm
 W 200 kg

DOUBLE
 L 1550 mm
 W 650 mm
 H 440 mm
 W 386 kg

CURVED
 L 1806 mm
 W 768 mm
 H 440 mm
 W 401 kg

MATERIALI: DISPONIBILE IN AGGREGATO DI PIETRE DI MARMO NATURALI O IN GRANITO BIANCO.
FINITURA: SABBIATURA, CON BORDO SUPERIORE LEVIGATO O BOCCIARDATO.



PRECIOUS STONES /
 PIETRE PREZIOSE



WHITE GRANITE /
 GRANITO BIANCO









BERRY / BELLITALIA® DESIGN DEPARTMENT

MATERIALS: RECONSTITUTED NATURAL MARBLE STONES OR WHITE GRANITE.

FINISHING: SANDBLASTED WITH POLISHED OR BUSH HAMMERED UPPER RIM.



L 1000 mm
W 1000 mm
H 711 mm
W 760 kg

MATERIALI: DISPONIBILE IN AGGREGATO DI PIETRE DI MARMO NATURALI O IN GRANITO BIANCO.

FINITURA: SABBIATURA, CON BORDO SUPERIORE LEVIGATO O BOCCIARDATO.

PRECIOUS STONES /
PIETRE PREZIOSE



WHITE GRANITE /
GRANITO BIANCO



ONDA - ONDA CURVA /

BELLITALIA® DESIGN DEPARTMENT

MATERIALS: RECONSTITUTED NATURAL MARBLE STONES OR WHITE GRANITE.

FINISHING: SANDBLASTED WITH POLISHED SEAT SURFACE.

ACCESSORIES: ARRANGED TO HOUSE LED SPOTLIGHTS. PROVIDED WITH LEVELLING SYSTEM.

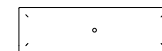
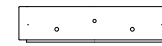

ONDA
L 2000 mm
W 600 mm
H 470 mm
W 790 kg



ONDA CURVA
L 1990 mm
W 752 mm
H 470 mm
W 730 kg



MATERIALI: DISPONIBILE IN AGGREGATO DI PIETRE DI MARMO NATURALI O IN GRANITO BIANCO.

FINITURA: SABBIATURA CON PIANO DI SEDUTA LEVIGATO.

ACCESSORI: PREDISPOSIZIONE PER ALLOGGIAMENTO DI FARETTI A LED. CON LIVELLAMENTO.

PRECIOUS STONES /
PIETRE PREZIOSE



WHITE GRANITE /
GRANITO BIANCO









COROLLA /

BELLITALIA® DESIGN DEPARTMENT

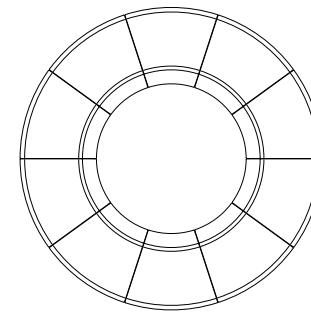
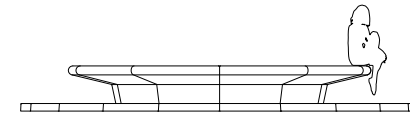

Ø 4000 mm
H 500 mm
W 7585 kg

MATERIALS: RECONSTITUTED NATURAL MARBLE STONES OR WHITE GRANITE.

FINISHING: SANDBLASTED WITH POLISHED OR BUSH HAMMERED SEAT SURFACE.

ACCESSORIES: SANDBLASTED PERIMETRAL PLATES.

MATERIALI: DISPONIBILE IN AGGREGATO DI PIETRE DI MARMO NATURALI O IN GRANITO BIANCO.

FINITURA: SABBIAIATURA CON PIANO DI SEDUTA LEVIGATO O BOCCIARDATO.

ACCESSORI: PIASTRE PERIMETRALI SABBIAIE.



PRECIOUS STONES /
PIETRE PREZIOSE



WHITE GRANITE /
GRANITO BIANCO







MUG /

BELLITALIA® DESIGN DEPARTMENT

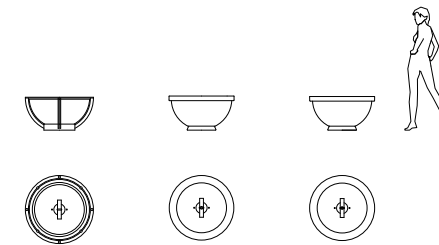

Ø 860 / 900 mm
 H 451 / 435 mm
 W 140 / 125 kg

MATERIALS: RECONSTITUTED NATURAL MARBLE STONES, WHITE GRANITE, GREY CONCRETE OR COPPER.
FINISHING: SANDBLASTED.
ACCESSORIES: STEEL FRAME. PROVIDED WITH LEVELLING SYSTEM.

MATERIALI: DISPONIBILE IN AGGREGATO DI PIETRE DI MARMO NATURALI, GRANITO BIANCO O CEMENTO GRIGIO.
FINITURA: SABBIATURA.
ACCESSORI: STRUTTURA IN ACCIAIO O GUSCIO IN RAME. CON LIVELLAMENTO.



PRECIOUS STONES /
 PIETRE PREZIOSE



WHITE GRANITE /
 GRANITO BIANCO



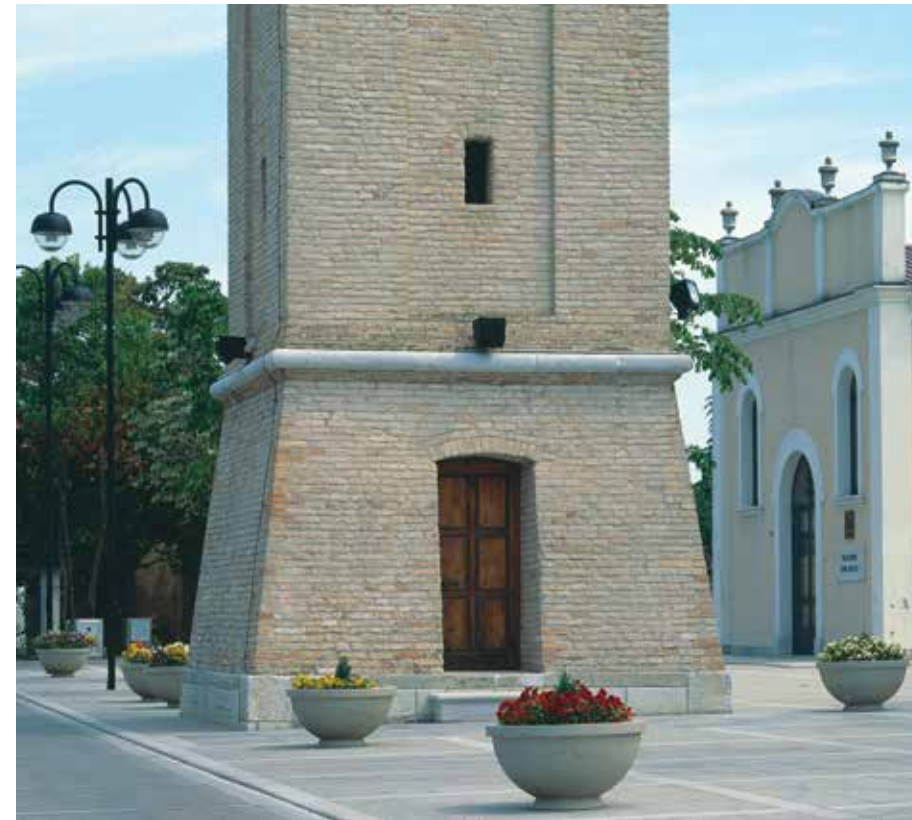

A SWING, B SWING /

BELLITALIA® DESIGN DEPARTMENT

MATERIALS: RECONSTITUTED NATURAL MARBLE STONES, WHITE GRANITE OR GREY CONCRETE.

FINISHING: SANDBLASTED.

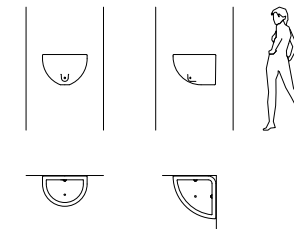

A SWING	B SWING
L 590 mm	L 565 mm
W 400 mm	W 565 mm
H 400 mm	H 400 mm
W 66 kg	W 87 kg

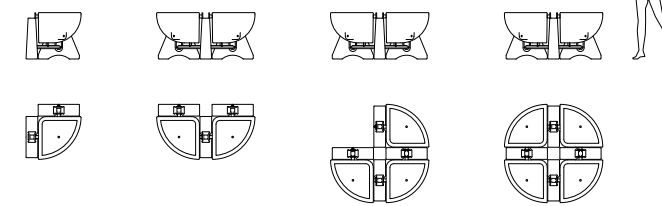

B SWING	B SWING	B SWING	B SWING
90°	180°	270°	360°

PRECIOUS STONES /
PIETRE PREZIOSE



WHITE GRANITE /
GRANITO BIANCO



C SWING /

BELLITALIA® DESIGN DEPARTMENT

MATERIALS: RECONSTITUTED NATURAL MARBLE STONES, WHITE GRANITE OR GREY CONCRETE.
FINISHING: SANDBLASTED.

MATERIALI: DISPONIBILE IN AGGREGATO DI PIETRE DI MARMO NATURALI, GRANITO BIANCO O CEMENTO GRIGIO.
FINITURA: SABBIATURA.

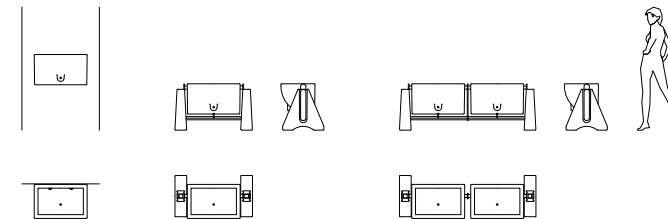

BASE
 L 1025 / 1805 mm
 W 568 mm
 H 613 mm
 W 238 / 361 kg

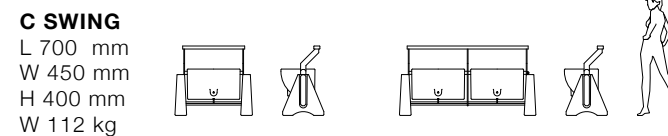

C SWING
 L 700 mm
 W 450 mm
 H 400 mm
 W 112 kg

RAIL
 L 1025 / 1805 mm
 W 568 mm
 H 918 mm
 W 246 / 376 kg

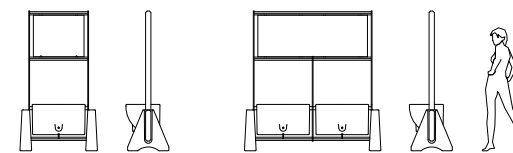

FRAME
 L 1025 / 1805 mm
 W 568 mm
 H 1848 mm
 W 258 / 388 kg

PRECIOUS STONES /
 PIETRE PREZIOSE



WHITE GRANITE /
 GRANITO BIANCO







CASSIOPEA /

BELLITALIA® DESIGN DEPARTMENT

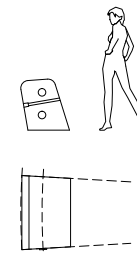

L 979 mm
W 644 mm
H 675 mm
W 750 kg

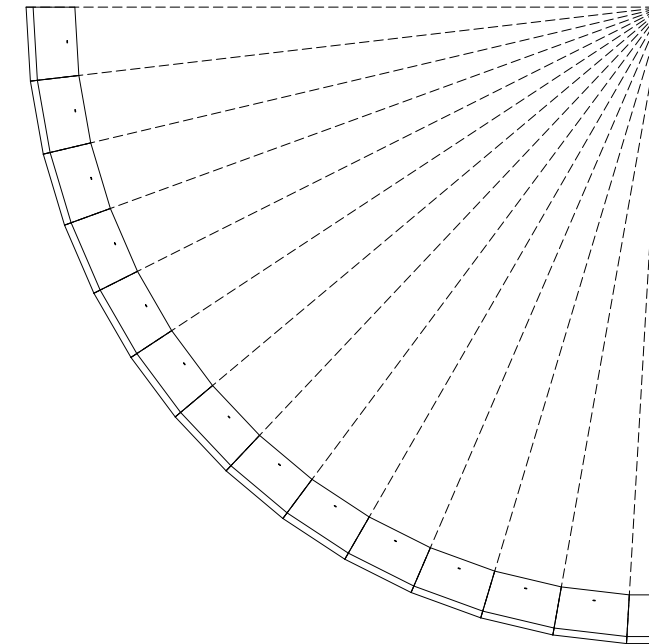

MATERIALS: RECONSTITUTED NATURAL MARBLE STONES OR WHITE GRANITE.

FINISHING: FINE SANDBLASTED.

ACCESSORIES: ARRANGED TO HOUSE LED SPOTLIGHTS.

MATERIALI: DISPONIBILE IN AGGREGATO DI PIETRE DI MARMO NATURALI O IN GRANITO BIANCO.

FINITURA: SABBIATURA FINE.

ACCESSORI: PREDISPOSIZIONE PER ALLOGGIAMENTO DI FARETTI A LED.

PRECIOUS STONES /
PIETRE PREZIOSE



WHITE GRANITE /
GRANITO BIANCO





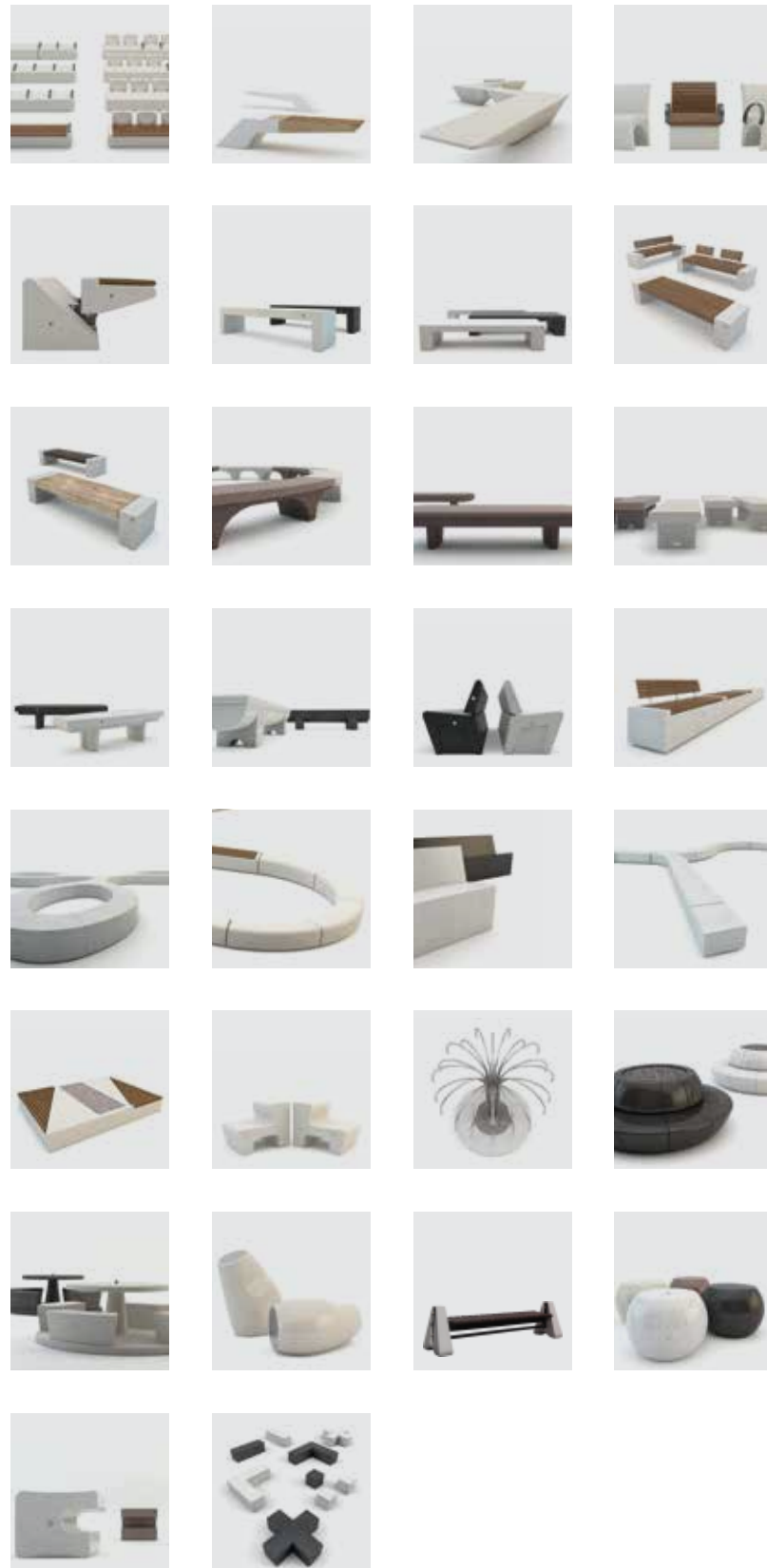

Lounge p. 268	Wing p. 280	Arrow p. 288	Gea p. 296
Minerva p. 306	Venezia p. 312	Eraclea p. 318	Eraclea Legno p. 324
Eraclea Gres p. 330	Romana p. 334	Afrodite p. 338	Aurelia p. 342
Città p. 348	Menhir p. 352	Atena p. 356	Demetra p. 362
Demetra Curva p. 370	Onda p. 374	Holly p. 384	Kubb p. 390
Smart p. 394	Arena p. 400	Olimpo Lighting Tree p. 408	Olimpo Backrest p. 416
Icaro p. 422	Bios p. 426	Swing p. 430	Apollo p. 434
Quadro p. 440	Labyrinth p. 444		

BENCHES / PANCHE



LOUNGE /

BELLITALIA® DESIGN DEPARTMENT

MATERIALS: WHITE GRANITE.
FINISHING: SANDBLASTED OR NATURAL SMOOTH.
ACCESSORIES: CONCRETE BACKREST, WOODEN SEAT AND STEEL OR STAINLESS STEEL ARMREST.

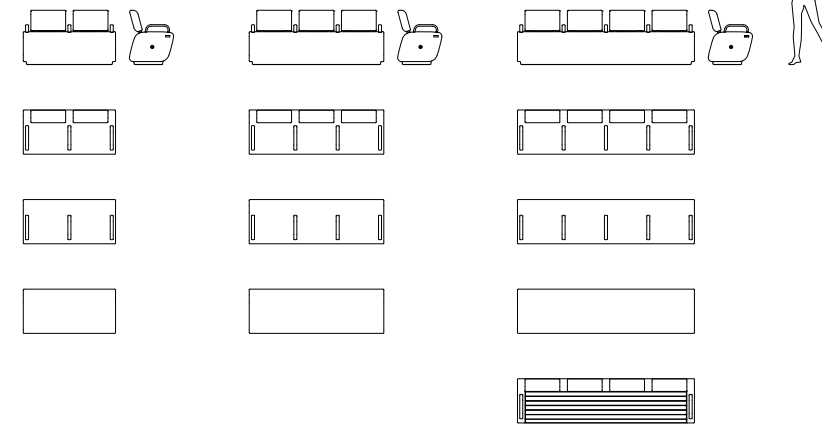

FOR 2
 L 1220 mm
 W 585 mm
 H 435 / 718 mm
 W 470 / 530 kg

FOR 3
 L 1780 mm
 W 585 mm
 H 435 / 718 mm
 W 650 / 740 kg

FOR 4
 L 2340 mm
 W 585 mm
 H 435 / 718 mm
 W 870 / 990 kg

PRECIOUS STONES /
 PIETRE PREZIOSE



WHITE GRANITE /
 GRANITO BIANCO



WOOD /
 LEGNO



MATERIALI: GRANITO BIANCO.
FINITURA: SABBIATURA O LISCIO NATURALE.
ACCESSORI: SCHIENALE IN CEMENTO, INSERTO IN LEGNO E POGGIABRACCIO IN ACCIAIO ZINCATO O ACCIAIO INOX.

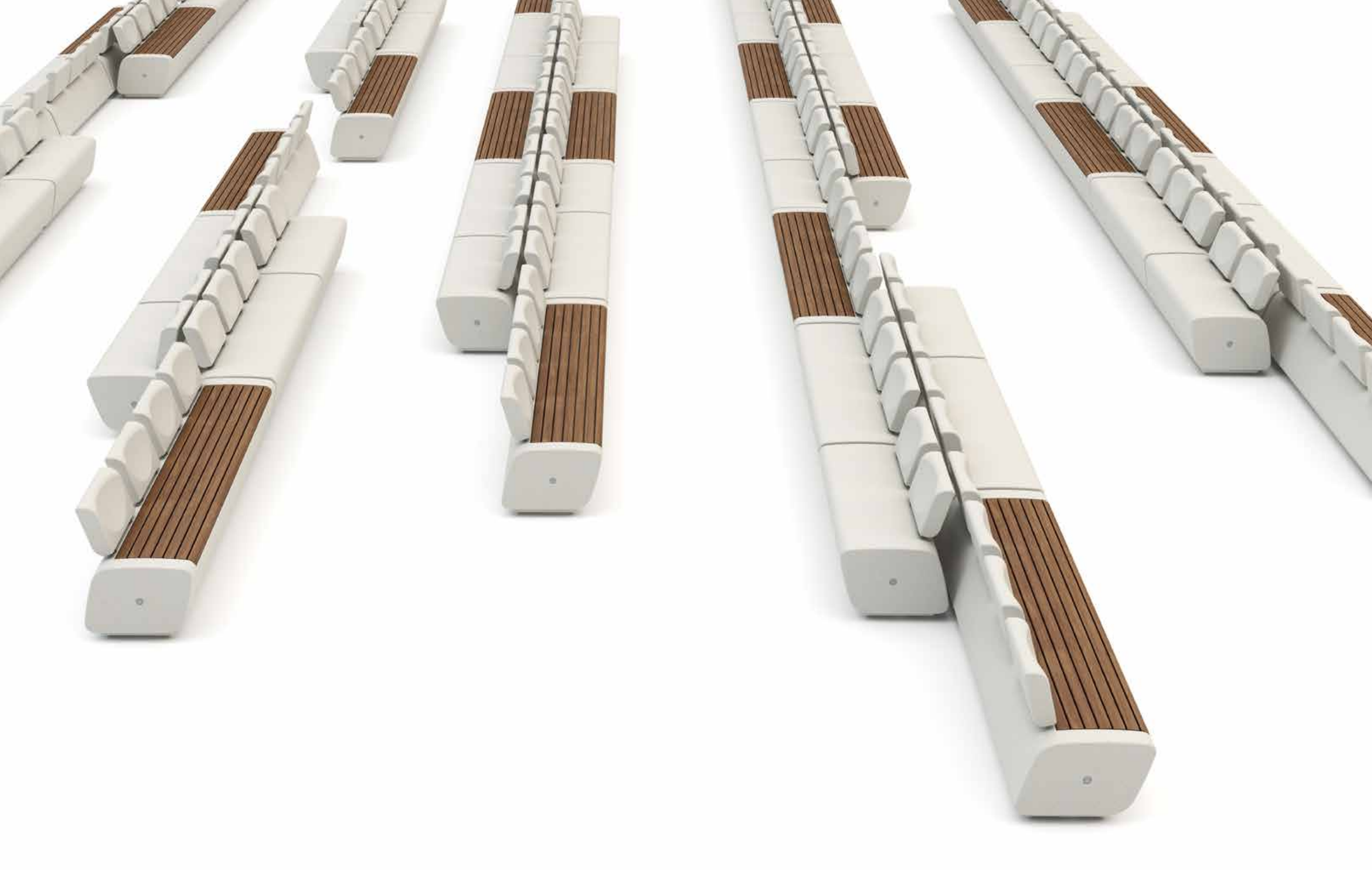





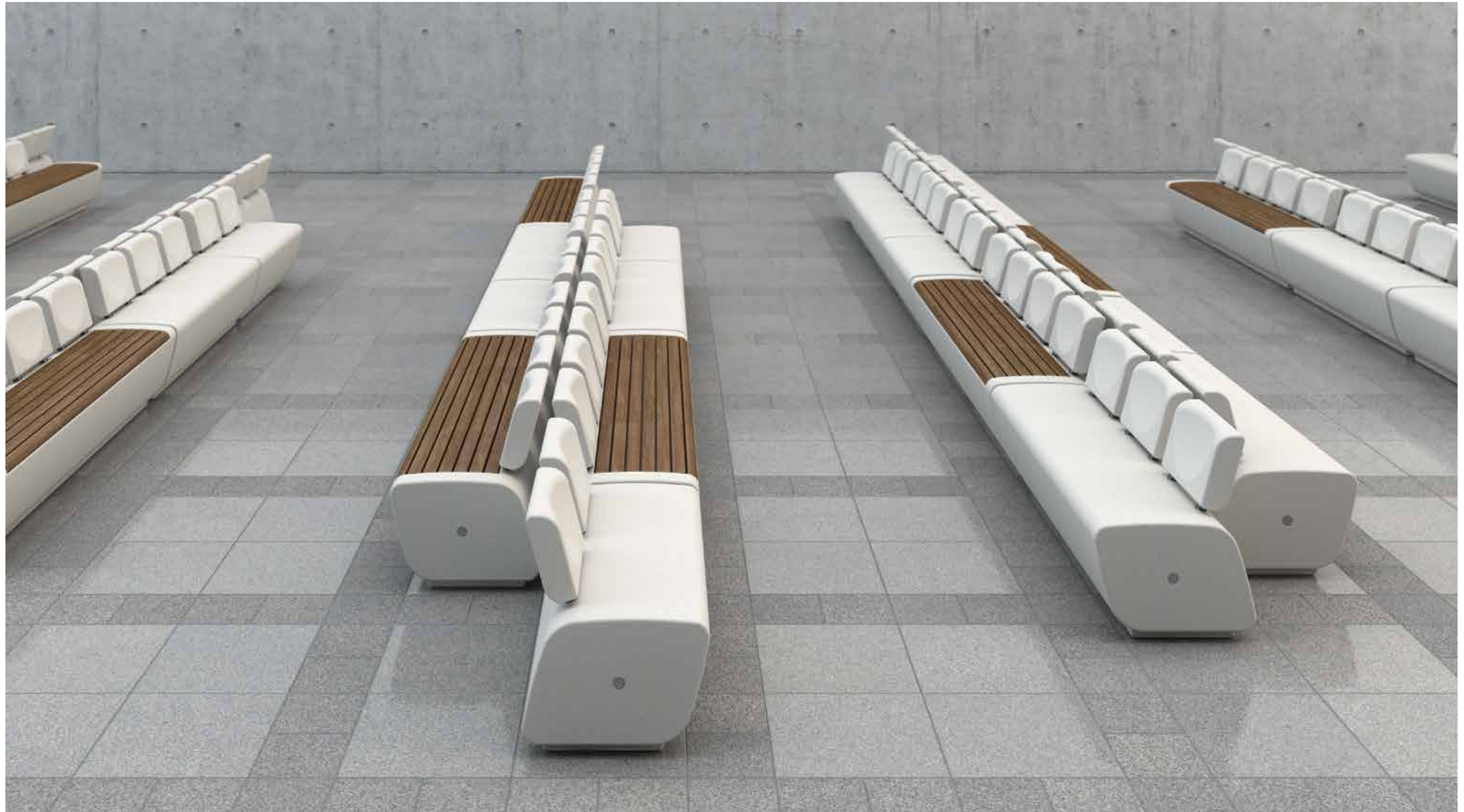



WING / DEL PONTE, ZAMBELLI

MATERIALS: RECONSTITUTED NATURAL MARBLE STONES OR WHITE GRANITE AND WOOD.
FINISHING: FINE SANDBLASTED.

MATERIALI: DISPONIBILE IN AGGREGATO DI PIETRE DI MARMO NATURALI, GRANITO BIANCO E LEGNO.
FINITURA: SABBIATURA FINE.

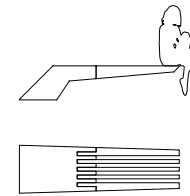

L: 2114 mm
W: 634 mm
H: 450 mm
W: 382 Kg

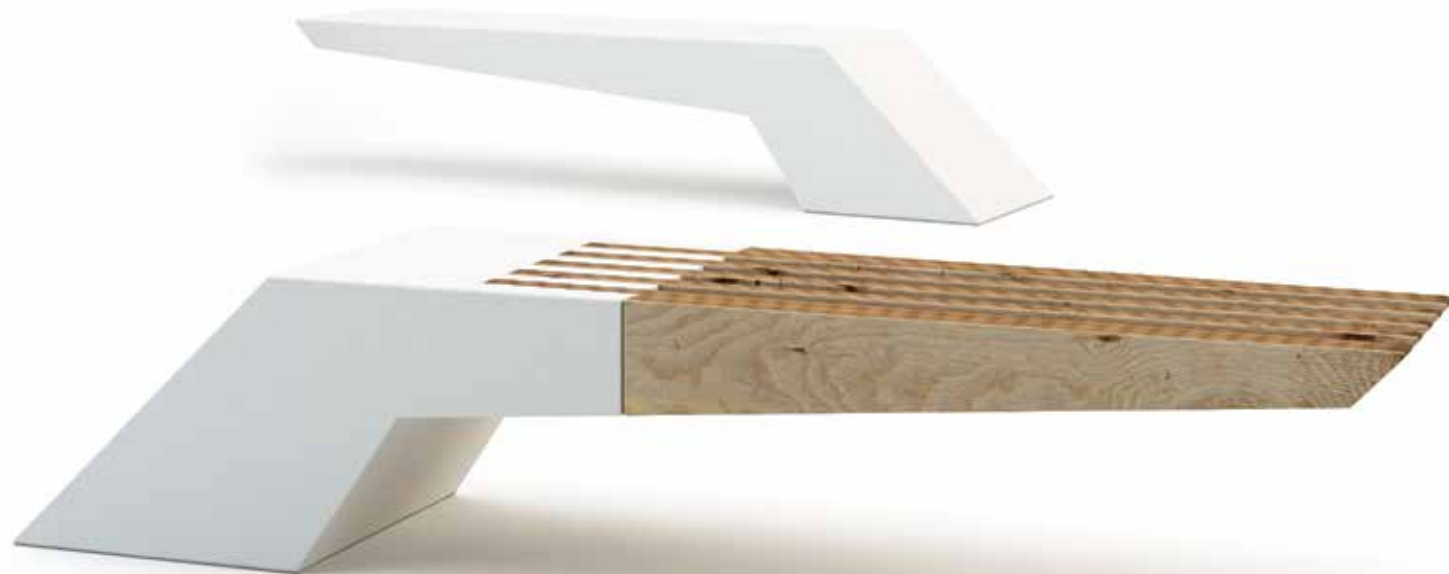

PRECIOUS STONES /
PIETRE PREZIOSE



WHITE GRANITE /
GRANITO BIANCO



WOOD /
LEGNO





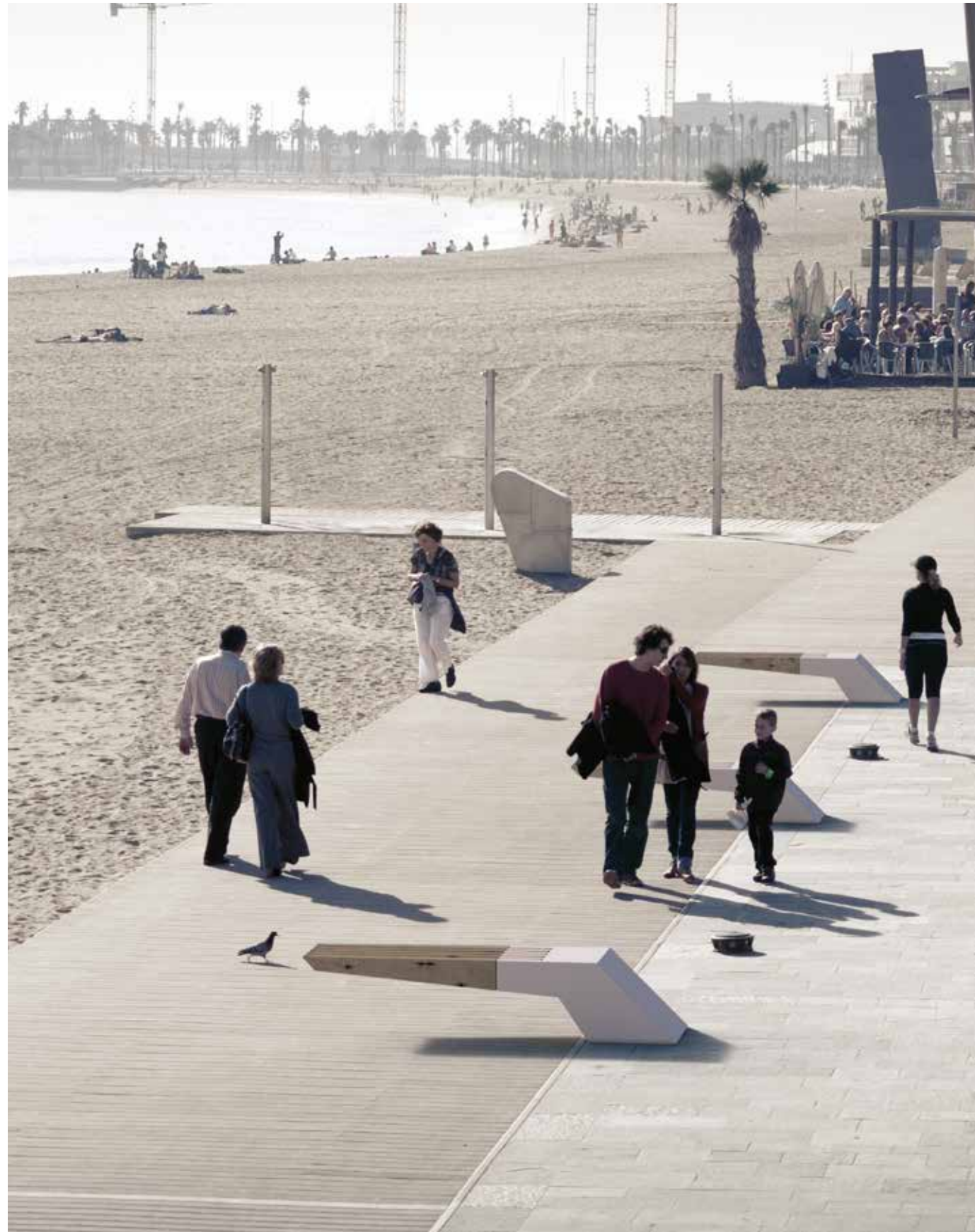



ARROW / C+S ARCHITECTS

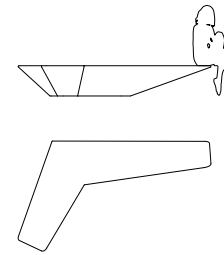

L: 2550 mm
W: 1456 mm
H: 400 mm
W: 819 Kg

MATERIALS: RECONSTITUTED NATURAL MARBLE STONES OR WHITE GRANITE.

FINISHING: SANDBLASTED WITH POLISHED SEAT SURFACE.

MATERIALI: DISPONIBILE IN AGGREGATO DI PIETRE DI MARMO NATURALI O IN GRANITO BIANCO.

FINITURA: LEVIGATURA SUL PIANO DI SEDUTA.



PRECIOUS STONES /
PIETRE PREZIOSE



WHITE GRANITE /
GRANITO BIANCO



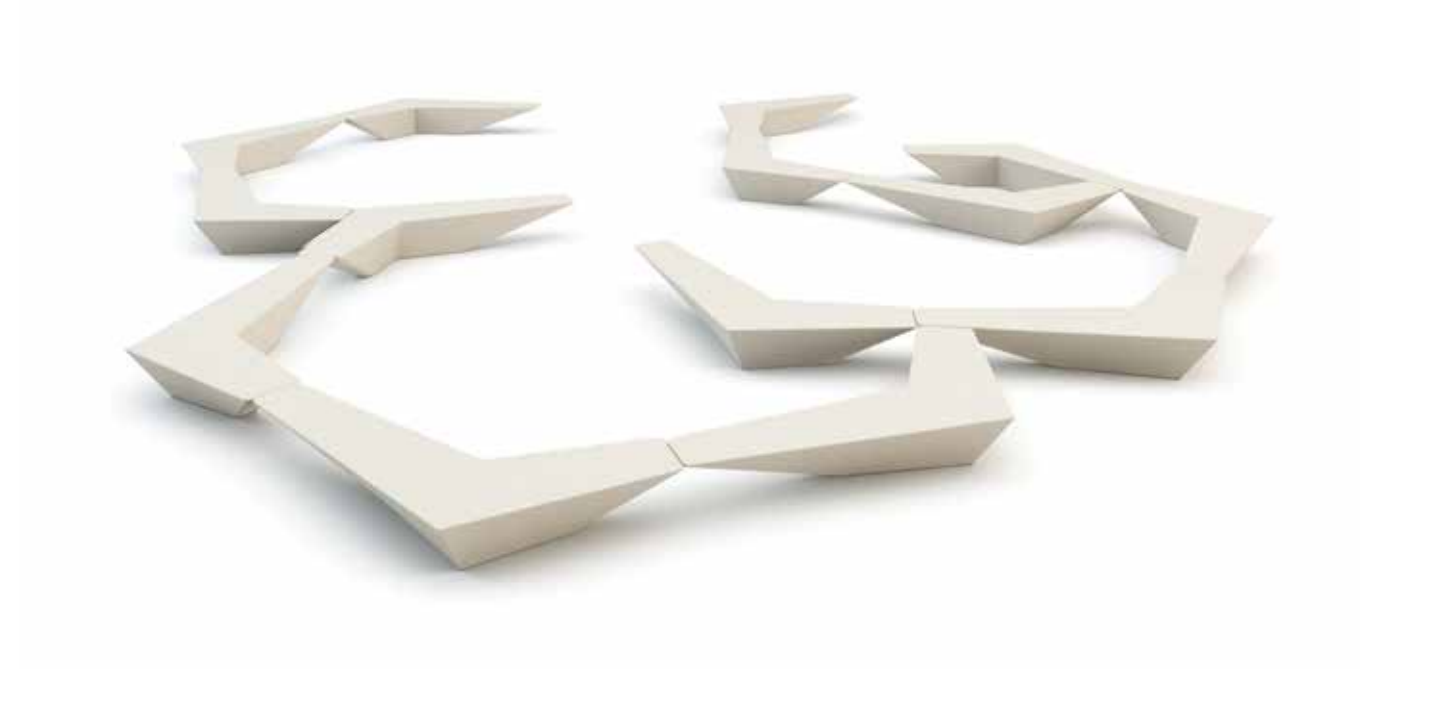
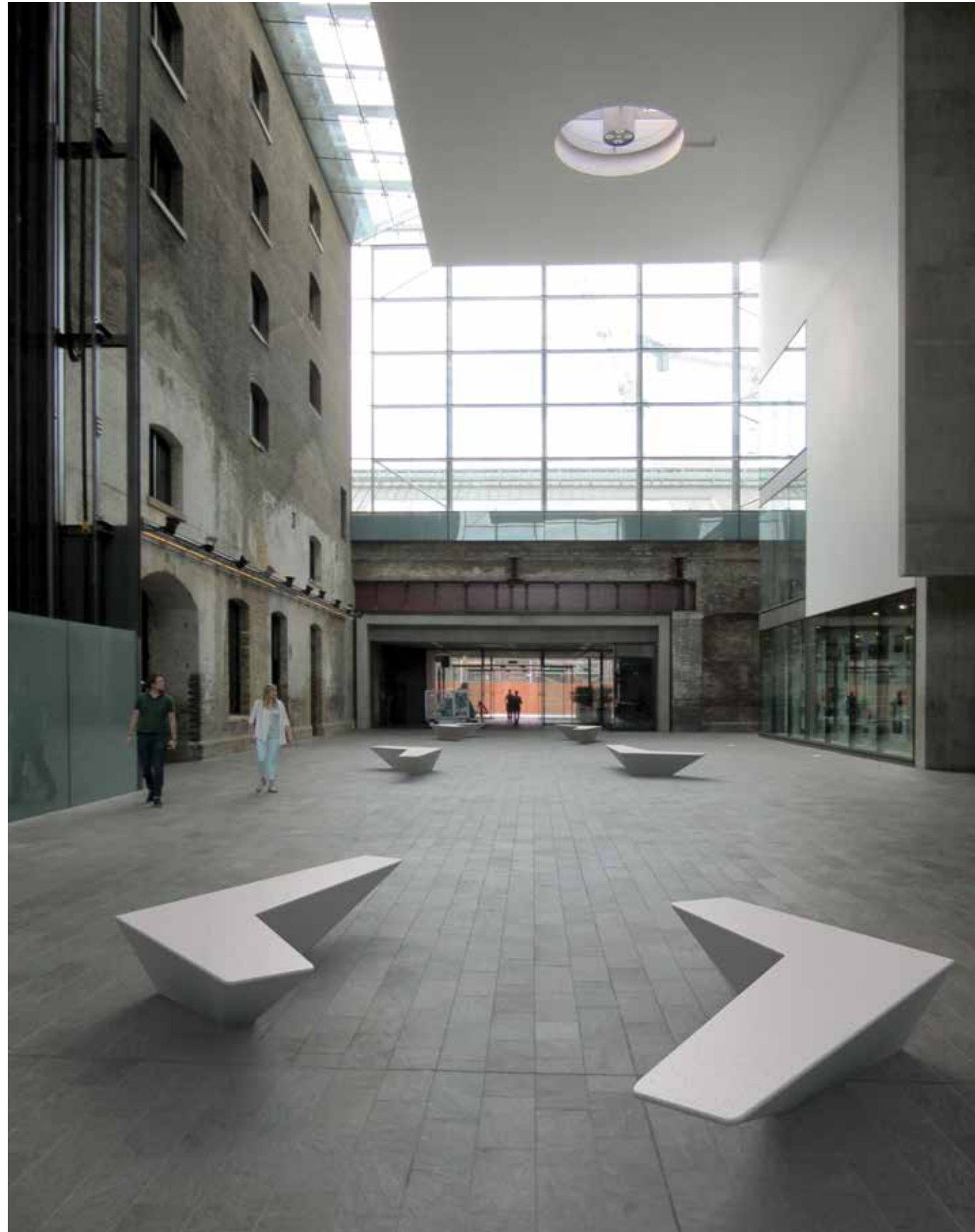







GEA /

BELLITALIA® DESIGN DEPARTMENT

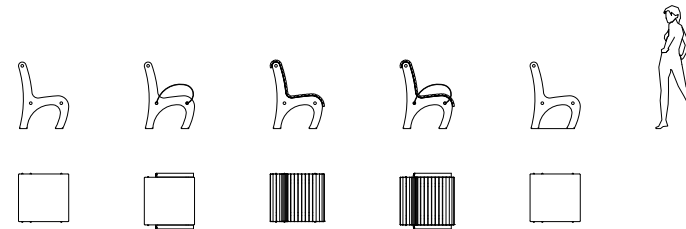

L: 630 mm
W: 664 mm
H: 880 mm
W: 290 kg

MATERIALS: RECONSTITUTED NATURAL MARBLE STONES OR WHITE GRANITE.

FINISHING: FINE SANDBLASTED.

ACCESSORIES: STEEL OR STAINLESS STEEL ARMRESTS AND WOODEN SLATS CLADDING.

MATERIALI: DISPONIBILE IN AGGREGATO DI PIETRE DI MARMO NATURALI O IN GRANITO BIANCO.

FINITURA: SABBIAATURA FINE.
ACCESSORI: POGGIABRACCIO IN ACCIAIO ZINCATO O ACCIAIO INOX E RIVESTIMENTO IN LISTELLI DI LEGNO.

PRECIOUS STONES /
PIETRE PREZIOSE



WHITE GRANITE /
GRANITO BIANCO



WOOD /
LEGNO











MINERVA /

BELLITALIA® DESIGN DEPARTMENT

MATERIALS: RECONSTITUTED NATURAL MARBLE STONES, WHITE GRANITE OR GREY CONCRETE, WITH WOODEN SEAT.

FINISHING: SANDBLASTED.

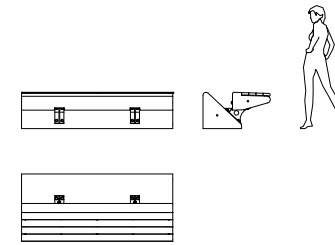

L: 2000 mm
W: 890 mm
H: 480 mm
W: 1170 kg

MATERIALI: DISPONIBILE IN AGGREGATO DI PIETRE DI MARMO NATURALI, GRANITO BIANCO O CEMENTO GRIGIO, CON SEDUTA IN LISTELLI DI LEGNO.

FINITURA: SABBIATURA.

PRECIOUS STONES /
PIETRE PREZIOSE



WHITE GRANITE /
GRANITO BIANCO



WOOD /
LEGNO







VENEZIA /

BELLITALIA® DESIGN DEPARTMENT

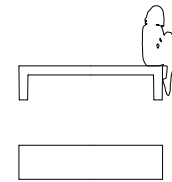

L: 1900 mm
W: 450 mm
H: 450 mm
W: 340 kg

MATERIALS: RECONSTITUTED NATURAL MARBLE STONES OR WHITE GRANITE.

FINISHING: SANDBLASTED WITH POLISHED OR BUSH HAMMERED SEAT SURFACE.

MATERIALI: DISPONIBILE IN AGGREGATO DI PIETRE DI MARMO NATURALI O IN GRANITO BIANCO.

FINITURA: LEVIGATURA O BOCCIARDATURA SUL PIANO DI SEDUTA.



PRECIOUS STONES /
PIETRE PREZIOSE



WHITE GRANITE /
GRANITO BIANCO







ERACLEA /

BELLITALIA® DESIGN DEPARTMENT

MATERIALS: RECONSTITUTED NATURAL MARBLE STONES OR WHITE GRANITE.

FINISHING: SANDBLASTED WITH POLISHED OR BUSH HAMMERED SEAT SURFACE.

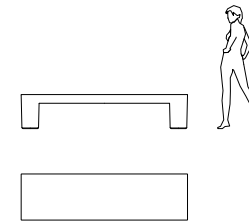

L: 2200 mm
W: 610 mm
H: 450 mm
W: 594 kg

MATERIALI: DISPONIBILE IN AGGREGATO DI PIETRE DI MARMO NATURALI O IN GRANITO BIANCO.

FINITURA: LEVIGATURA O BOCCIARDATURA SUL PIANO DI SEDUTA.



PRECIOUS STONES /
PIETRE PREZIOSE



WHITE GRANITE /
GRANITO BIANCO







ERACLEA LEGNO / MATTEO CESCHINI

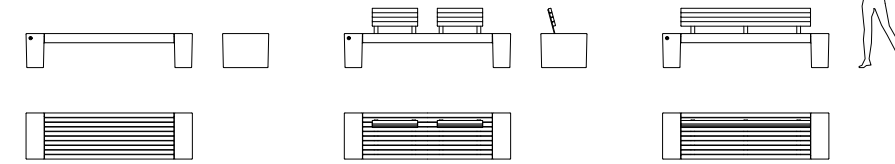

L: 2200 mm
W: 650 mm
H: 450 / 784 mm
W: 500 / 514 kg

MATERIALS: RECONSTITUTED NATURAL MARBLE STONES OR WHITE GRANITE WITH WOODEN SLATS.

FINISHING: SANDBLASTED WITH POLISHED OR BUSH HAMMERED TOP SURFACE.

ACCESSORIES: SINGLE OR COMPLETE WOODEN BACKREST.

MATERIALI: DISPONIBILE IN AGGREGATO DI PIETRE DI MARMO NATURALI O IN GRANITO BIANCO CON SEDUTA IN DOGHE DI LEGNO.

FINITURA: SABBIATURA CON LEVIGATURA O BOCCIARDATURA SUL PIANO SUPERIORE.

ACCESSORI: SCHIENALE IN LEGNO COMPLETO O SINGOLO.

PRECIOUS STONES /
PIETRE PREZIOSE



WHITE GRANITE /
GRANITO BIANCO



WOOD /
LEGNO







ERACLEA GRES / MATTEO CESCHINI

MATERIALS: RECONSTITUTED NATURAL MARBLE STONES OR WHITE GRANITE WITH GRES WOODEN SEAT.

FINISHING: SANDBLASTED WITH POLISHED OR BUSH HAMMERED TOP SURFACE.

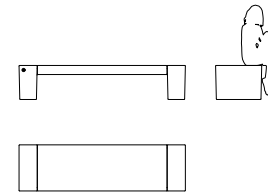

L: 2200 mm
W: 650 mm
H: 450 mm
W: 505 kg



MATERIALI: DISPONIBILE IN AGGREGATO DI PIETRE DI MARMO NATURALI O IN GRANITO BIANCO CON SEDUTA IN GRES.

FINITURA: SABBIATURA CON LEVIGATURA O BOCCIARDATURA SUL PIANO SUPERIORE.

PRECIOUS STONES /
PIETRE PREZIOSE



WHITE GRANITE /
GRANITO BIANCO



GRES /
GRES





ROMANA /

BELLITALIA® DESIGN DEPARTMENT

MATERIALS: RECONSTITUTED NATURAL MARBLE STONES OR WHITE GRANITE.

FINISHING: SANDBLASTED WITH POLISHED OR BUSH HAMMERED SEAT SURFACE.

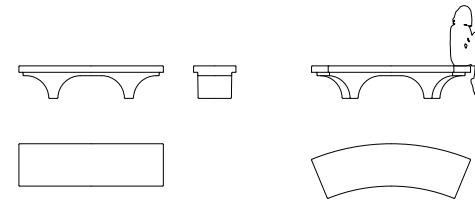

DRITTA

L: 1910 mm
W: 560 mm
H: 430 mm
W: 490 kg

CURVA

L: 2109 mm
W: 725 mm
H: 430 mm
W: 530 kg

MATERIALI: DISPONIBILE IN AGGREGATO DI PIETRE DI MARMO NATURALI O IN GRANITO BIANCO.

FINITURA: LEVIGATURA O BOCCIARDATURA SUL PIANO DI SEDUTA.



PRECIOUS STONES /
PIETRE PREZIOSE



WHITE GRANITE /
GRANITO BIANCO





AFRODITE /

BELLITALIA® DESIGN DEPARTMENT

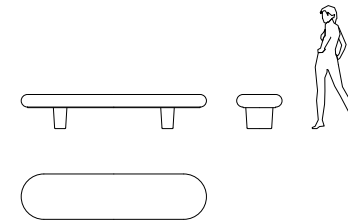

L: 2450 mm
W: 600 mm
H: 451 mm
W: 610 kg

MATERIALS: RECONSTITUTED NATURAL MARBLE STONES OR WHITE GRANITE.

FINISHING: SANDBLASTED WITH POLISHED OR BUSH HAMMERED SEAT SURFACE.

MATERIALI: DISPONIBILE IN AGGREGATO DI PIETRE DI MARMO NATURALI O IN GRANITO BIANCO.

FINITURA: LEVIGATURA O BOCCIARDATURA SUL PIANO DI SEDUTA.



PRECIOUS STONES /
PIETRE PREZIOSE



WHITE GRANITE /
GRANITO BIANCO





AURELIA /

BELLITALIA® DESIGN DEPARTMENT

MATERIALS: RECONSTITUTED NATURAL MARBLE STONES OR WHITE GRANITE.

FINISHING: SANDBLASTED WITH POLISHED OR BUSH HAMMERED SEAT SURFACE.

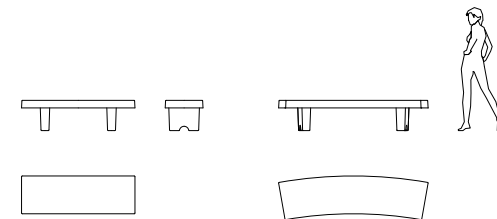

DRITTA
L: 1500 mm
W: 500 mm
H: 400 mm
W: 243 kg

CURVA
L: 1979 mm
W: 578 mm
H: 400 mm
W: 290 kg

MATERIALI: DISPONIBILE IN AGGREGATO DI PIETRE DI MARMO NATURALI O IN GRANITO BIANCO.

FINITURA: LEVIGATURA O BOCCIARDATURA SUL PIANO DI SEDUTA.



PRECIOUS STONES /
PIETRE PREZIOSE



WHITE GRANITE /
GRANITO BIANCO







CITTA' /

BELLITALIA® DESIGN DEPARTMENT

MATERIALS: RECONSTITUTED NATURAL MARBLE STONES, WHITE GRANITE OR GREY CONCRETE.

FINISHING: SANDBLASTED.

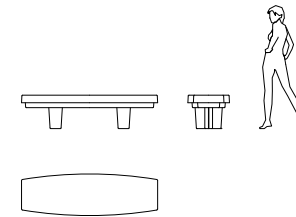

L: 1800 mm
W: 550 mm
H: 442 mm
W: 368 kg

MATERIALI: DISPONIBILE IN AGGREGATO DI PIETRE DI MARMO NATURALI, GRANITO BIANCO O CEMENTO GRIGIO.
FINITURA: SABBIATURA.



PRECIOUS STONES /
PIETRE PREZIOSE



WHITE GRANITE /
GRANITO BIANCO



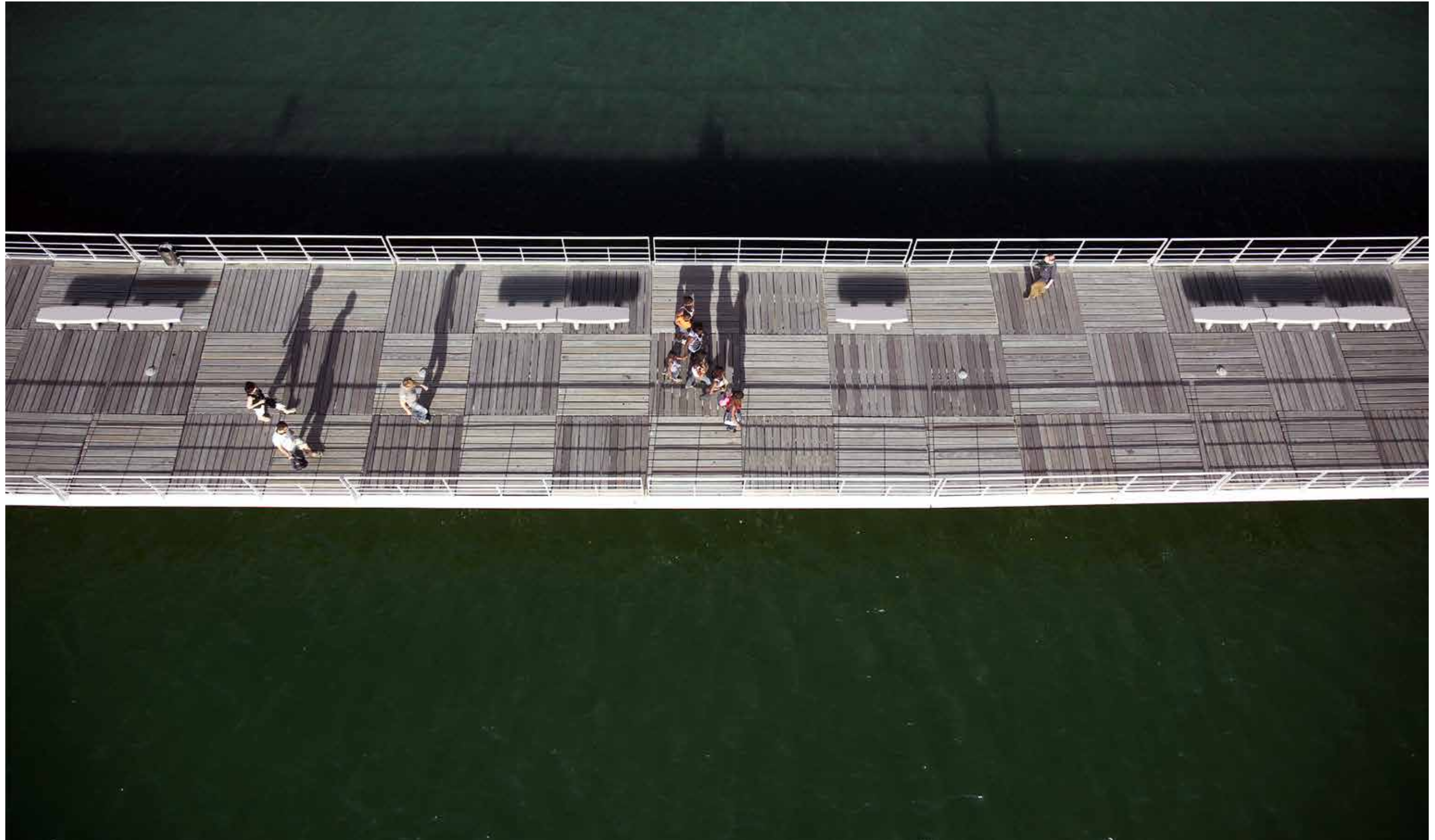

MENHIR /

BELLITALIA® DESIGN DEPARTMENT

MATERIALS: RECONSTITUTED NATURAL MARBLE STONES, WHITE GRANITE OR GREY CONCRETE.

FINISHING: SANDBLASTED.

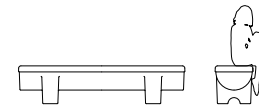

L: 2200 mm
W: 500 mm
H: 500 mm
W: 780 kg

MATERIALI: DISPONIBILE IN AGGREGATO DI PIETRE DI MARMO NATURALI, GRANITO BIANCO O CEMENTO GRIGIO.
FINITURA: SABBIATURA.



PRECIOUS STONES /
PIETRE PREZIOSE



WHITE GRANITE /
GRANITO BIANCO





ATENA /

BELLITALIA® DESIGN DEPARTMENT

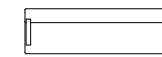
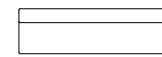
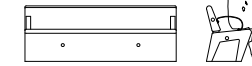
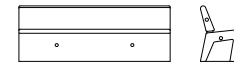

L: 2000 mm
W: 595 mm
H: 734 mm
W: 790 kg

MATERIALS: RECONSTITUTED NATURAL MARBLE STONES OR WHITE GRANITE.

FINISHING: SANDBLASTED WITH POLISHED OR BUSH HAMMERED SEAT SURFACE AND BACKREST.

ACCESSORIES: ARRANGED TO HOUSE LED SPOTLIGHTS, STEEL OR STAINLESS STEEL ARMREST.

MATERIALI: DISPONIBILE IN AGGREGATO DI PIETRE DI MARMO NATURALI O IN GRANITO BIANCO.

FINITURA: SABBIATA CON LEVIGATURA O BOCCIARDATURA SU SEDUTA E SCHIENALE.

ACCESSORI: PREDISPOSIZIONE PER ALLOGGIAMENTO DI FARETTI A LED, POGGIABRACCIO IN ACCIAIO ZINCATO O ACCIAIO INOX.

PRECIOUS STONES /
PIETRE PREZIOSE



WHITE GRANITE /
GRANITO BIANCO



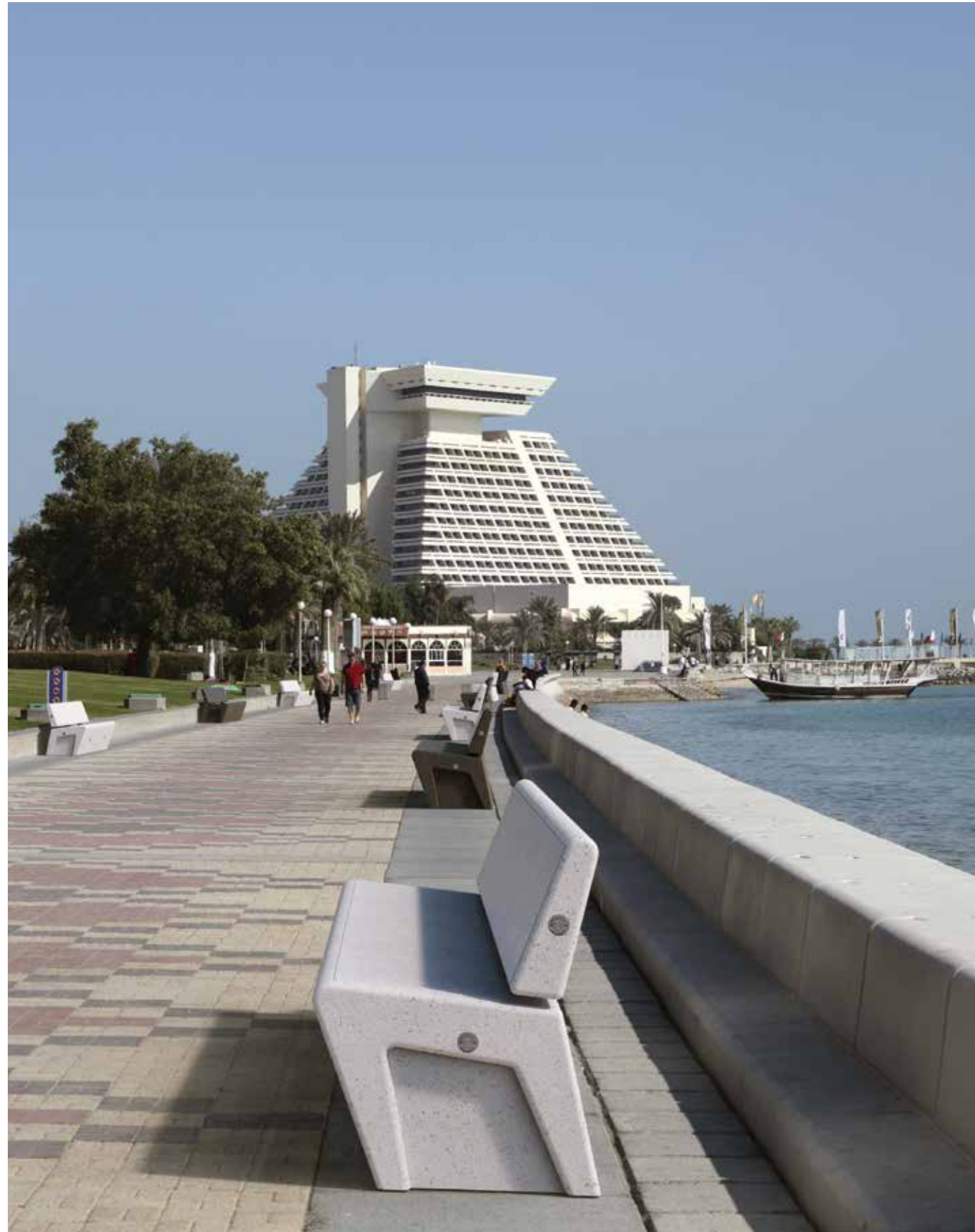



DEMETRA /

BELLITALIA® DESIGN DEPARTMENT

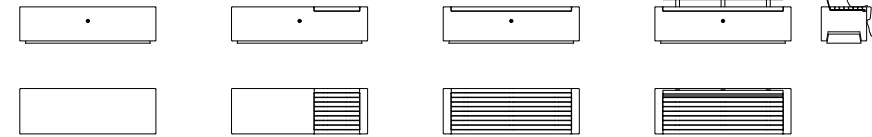

L: 1800 mm
W: 600 mm
H: 480 mm
W: 1170 kg

MATERIALS: RECONSTITUTED NATURAL MARBLE STONES OR WHITE GRANITE.

FINISHING: SANDBLASTED WITH POLISHED OR BUSH HAMMERED SEAT SURFACE.

ACCESSORIES: WOODEN INSERT SEAT, FULL SEAT OR BACKREST. PROVIDED WITH LEVELLING SYSTEM.

MATERIALI: DISPONIBILE IN AGGREGATO DI PIETRE DI MARMO NATURALI O IN GRANITO BIANCO.

FINITURA: SABBIATA, CON BOCCIARDATURA O LEVIGATURA SUL PIANO DI SEDUTA.

ACCESSORI: INSERTO, SEDUTA O SCHIENALE IN LEGNO. CON LIVELLAMENTO.



PRECIOUS STONES /
PIETRE PREZIOSE



WHITE GRANITE /
GRANITO BIANCO



WOOD /
LEGNO









DEMETRA CURVA /

BELLITALIA® DESIGN DEPARTMENT

MATERIALS: RECONSTITUTED NATURAL MARBLE STONES OR WHITE GRANITE.

FINISHING: SANDBLASTED WITH POLISHED OR BUSH HAMMERED SEAT SURFACE.

ACCESSORIES: PROVIDED WITH LEVELLING SYSTEM.

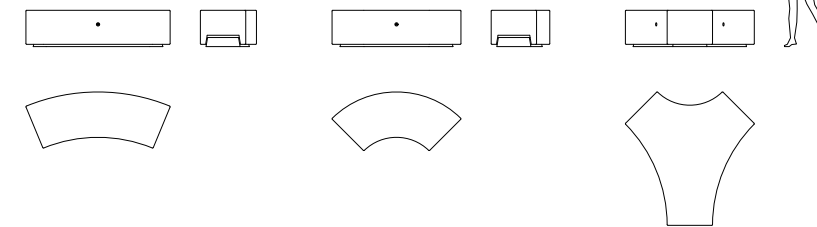

CURVA
L: 1705 mm
W: 775 mm
H: 480 mm
W: 1139 kg

CURVA PICCOLA
L: 1907 mm
W: 742 mm
H: 480 mm
W: 944 kg

YPSILON
L: 1764 mm
W: 1705 mm
H: 480 mm
W: 1881 kg

MATERIALI: DISPONIBILE IN AGGREGATO DI PIETRE DI MARMO NATURALI O IN GRANITO BIANCO.

FINITURA: SABBIATA, CON BOCCIARDATURA O LEVIGATURA SUL PIANO DI SEDUTA.

ACCESSORI: CON LIVELLAMENTO.



PRECIOUS STONES /
PIETRE PREZIOSE



WHITE GRANITE /
GRANITO BIANCO





ONDA /

LORENZO TOSOLINI

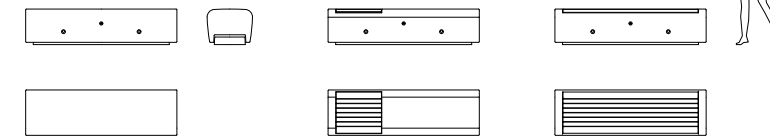

L: 2000 mm
W: 600 mm
H: 470 mm
W: 1155 kg

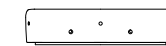

L: 1990 mm
W: 750 mm
H: 470 mm
W: 1060 kg

MATERIALS: RECONSTITUTED NATURAL MARBLE STONES OR WHITE GRANITE.

FINISHING: FINE SANDBLASTED OR POLISHED SEAT SURFACE.

ACCESSORIES: ARRANGED TO HOUSE LED SPOTLIGHTS, WITH SINGLE OR COMPLETE WOODEN SEAT. PROVIDED WITH LEVELLING SYSTEM.

MATERIALI: DISPONIBILE IN AGGREGATO DI PIETRE DI MARMO NATURALI O IN GRANITO BIANCO.

FINITURA: SABBIATURA FINE O LEVIGATURA SUL PIANO DI SEDUTA.

ACCESSORI: PREDISPOSIZIONE PER ALLOGGIAMENTO DI FARETTI A LED E INSERTO O SEDUTA COMPLETA IN LEGNO. CON LIVELLAMENTO.

PRECIOUS STONES /
PIETRE PREZIOSE



WHITE GRANITE /
GRANITO BIANCO



WOOD /
LEGNO











HOLLY / ANNACHIARA ELISEO

MATERIALS: RECONSTITUTED NATURAL MARBLE STONES OR WHITE GRANITE.

FINISHING: SANDBLASTED WITH POLISHED SEAT SURFACE AND BACKREST.

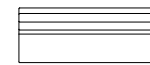
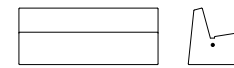

SHORT

L: 1840 mm
W: 723 mm
H: 747 mm
W: 1476 kg

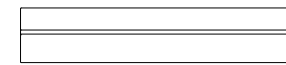
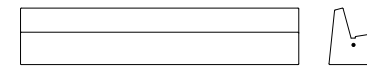

LONG

L: 3680 mm
W: 723 mm
H: 747 mm
W: 2952 kg

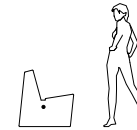

MATERIALI: DISPONIBILE IN AGGREGATO DI PIETRE DI MARMO NATURALI O IN GRANITO BIANCO.

FINITURA: SABBIATURA, CON LEVIGATURA SU PIANO DI SEDUTA E SCHIENALE.



PRECIOUS STONES /
PIETRE PREZIOSE



WHITE GRANITE /
GRANITO BIANCO









KUBB /

BELLITALIA® DESIGN DEPARTMENT

MATERIALS: RECONSTITUTED NATURAL MARBLE STONES OR WHITE GRANITE.
FINISHING: SANDBLASTED WITH POLISHED OR BUSH HAMMERED SEAT SURFACE.

MATERIALI: DISPONIBILE IN AGGREGATO DI PIETRE DI MARMO NATURALI O IN GRANITO BIANCO.
FINITURA: SABBIATURA, CON PIANO DI SEDUTA LEVIGATO O BOCCIARDATO.

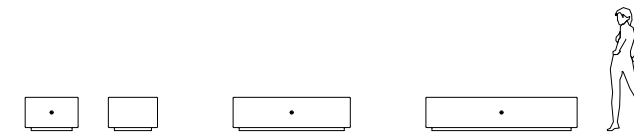

MONO	MID	DOUBLE
L: 700 mm	L: 1550 mm	L: 2000 mm
W: 650 mm	W: 650 mm	W: 650 mm
H: 440 mm	H: 440 mm	H: 440 mm
W: 472 kg	W: 1054 kg	W: 1362 kg

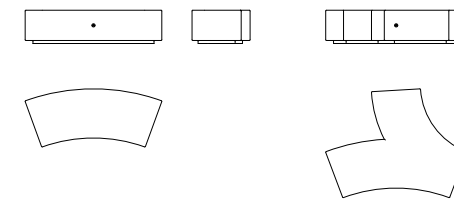

CURVED	CROSS
L: 1807 mm	L: 1864 mm
W: 768 mm	W: 1438 mm
H: 440 mm	H: 440 mm
W: 1104 kg	W: 1643 kg

PRECIOUS STONES /
PIETRE PREZIOSE

WHITE GRANITE /
GRANITO BIANCO





SMART /

BELLITALIA® DESIGN DEPARTMENT

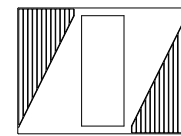
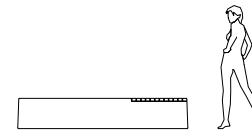

L: 2249 mm
W: 1664 mm
H: 400 mm
W: 1000 kg



MATERIALS: RECONSTITUTED NATURAL MARBLE STONES OR WHITE GRANITE.

FINISHING: SANDBLASTED WITH POLISHED OR BUSH HAMMERED SEAT SURFACE.

ACCESSORIES: WOODEN SLATS SEAT, INNER STEEL PLANTER.

MATERIALI: DISPONIBILE IN AGGREGATO DI PIETRE DI MARMO NATURALI O IN GRANITO BIANCO.

FINITURA: SABBIATURA CON LEVIGATURA O BOCCIARDATURA SUL PIANO DI SEDUTA.

ACCESSORI: SEDUTA CON DOGHE DI LEGNO, FIORIERA INTERNA IN ACCIAIO.

PRECIOUS STONES /
PIETRE PREZIOSE



WHITE GRANITE /
GRANITO BIANCO



WOOD /
LEGNO







ARENA /

BELLITALIA® DESIGN DEPARTMENT

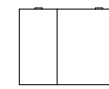
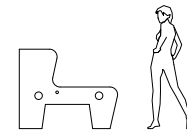

L: 1300 mm
W: 1000 mm
H: 1050 mm
W: 1750 kg

MATERIALS: RECONSTITUTED NATURAL MARBLE STONES OR WHITE GRANITE.

FINISHING: FINE SANDBLASTED.

ACCESSORIES: ARRANGED TO HOUSE LED SPOTLIGHTS.

MATERIALI: DISPONIBILE IN AGGREGATO DI PIETRE DI MARMO NATURALI O IN GRANITO BIANCO.

FINITURA: SABBIAATURA FINE.

ACCESSORI: PREDISPOSIZIONE PER ALLOGGIAMENTO DI FARETTI A LED.

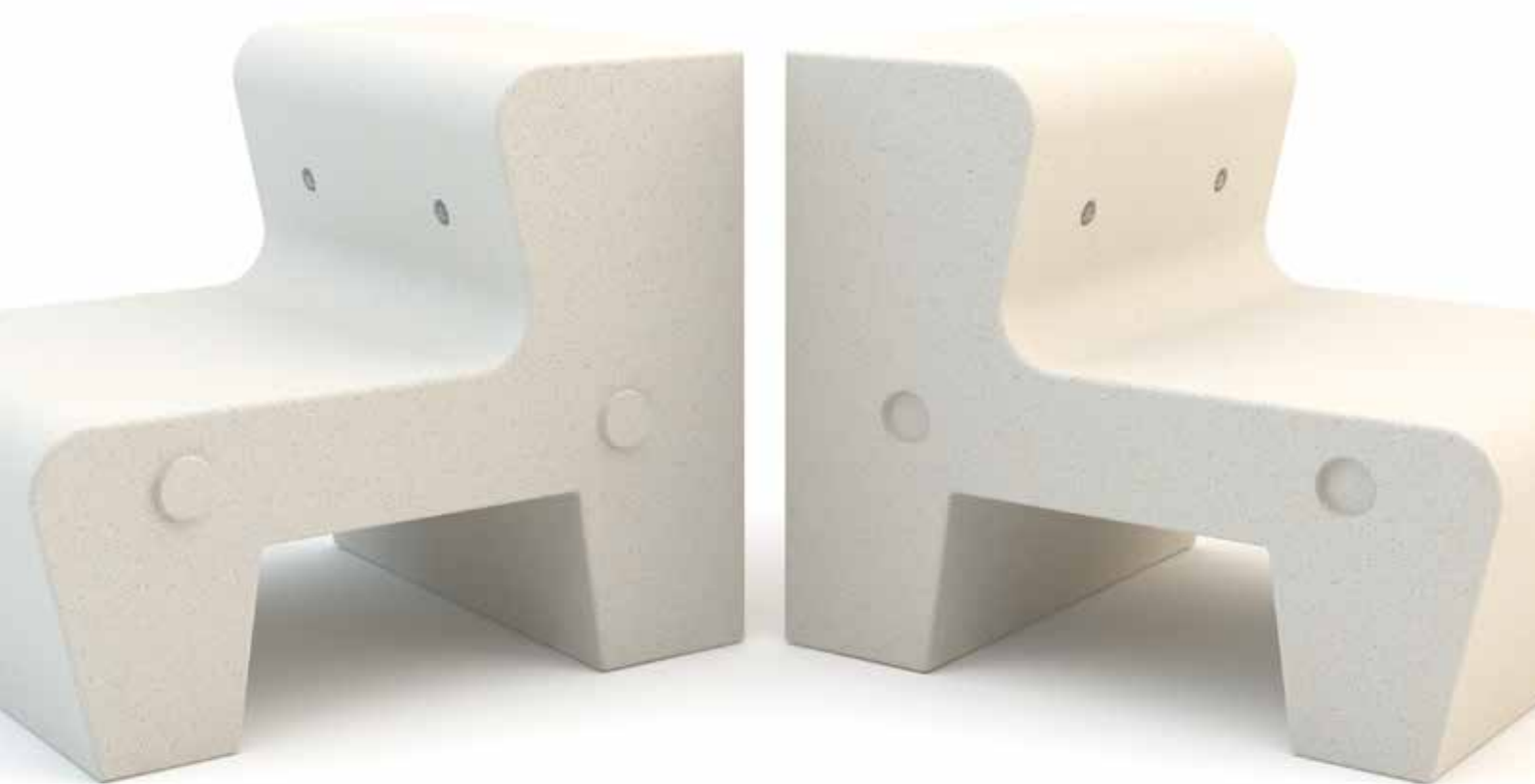

PRECIOUS STONES /
PIETRE PREZIOSE



WHITE GRANITE /
GRANITO BIANCO









OLIMPO LIGHTING TREE /

BELLITALIA® DESIGN DEPARTMENT

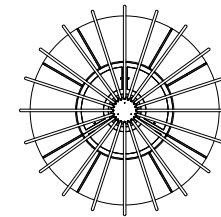
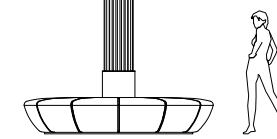

LIGHTING:
Ø: 2784 mm

BASE
Ø: 2500 mm
H: 3455 mm
W: 3808 kg

MATERIALS: RECONSTITUTED NATURAL MARBLE STONES OR WHITE GRANITE, WITH STAINLESS STEEL STRUCTURE.

FINISHING: POLISHED OR BUSH HAMMERED.

MATERIALI: DISPONIBILE IN AGGREGATO DI PIETRE DI MARMO NATURALI O IN GRANITO BIANCO. CON STRUTTURA IN ACCIAIO INOX.

FINITURA: LEVIGATURA O BOCCIARDATURA.

PRECIOUS STONES /
PIETRE PREZIOSE



WHITE GRANITE /
GRANITO BIANCO









OLIMPO BACKREST /

BELLITALIA® DESIGN DEPARTMENT

MATERIALS: RECONSTITUTED NATURAL MARBLE STONES OR WHITE GRANITE.

FINISHING: SANDBLASTED POLISHED OR BUSH HAMMERED.

MATERIALI: DISPONIBILE IN AGGREGATO DI PIETRE DI MARMO NATURALI O IN GRANITO BIANCO.

FINITURA: SABBIATURA, LEVIGATURA O BOCCIARDATURA.

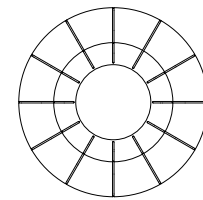
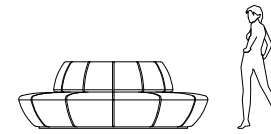

Ø: 2500 mm
H: 880 mm
W: 4500 kg



PRECIOUS STONES /
PIETRE PREZIOSE



WHITE GRANITE /
GRANITO BIANCO







ICARO /

BELLITALIA® DESIGN DEPARTMENT

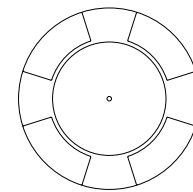
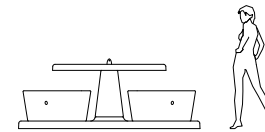

Ø: 2400 mm
H: 850 mm
W: 2366 kg

MATERIALS: RECONSTITUTED NATURAL MARBLE STONES OR WHITE GRANITE.

FINISHING: SANDBLASTED WITH POLISHED TABLE TOP AND SEAT SURFACE.

MATERIALI: DISPONIBILE IN AGGREGATO DI PIETRE DI MARMO NATURALI O IN GRANITO BIANCO.

FINITURA: SABBIATURA CON LEVIGATURA SU PIANI DI SEDUTA E TAVOLO.

PRECIOUS STONES /
PIETRE PREZIOSE



WHITE GRANITE /
GRANITO BIANCO





BIOS / LUISA FONTANA

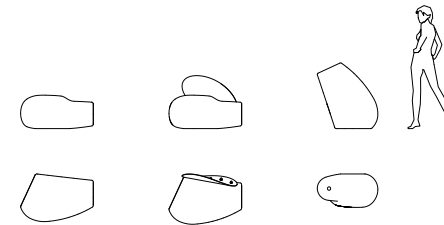

W: 962 mm
D: 630 mm
H: 442mm
W: 391 kg

W: 962 mm
D: 655 mm
H: 701 mm
W: 399 kg

W: 801mm
D: 442 mm
H: 868 mm
W: 388 kg

MATERIALS: RECONSTITUTED NATURAL MARBLE STONES OR WHITE GRANITE.

FINISHING: POLISHED OR FINE SANDBLASTED.

ACCESSORIES: STEEL OR STAINLESS STEEL BACKREST, BIG OR SMALL STAFF BEAD.

MATERIALI: DISPONIBILE IN AGGREGATO DI PIETRE DI MARMO NATURALI O IN GRANITO BIANCO.

FINITURA: LEVIGATURA O SABBIATURA FINE.

ACCESSORI: SCHIENALE, SCURETTO LATERALE GRANDE, SCURETTO LATERALE PICCOLO IN ACCIAIO ZINCATO O ACCIAIO INOX.



PRECIOUS STONES /
PIETRE PREZIOSE



WHITE GRANITE /
GRANITO BIANCO







SWING /

BELLITALIA® DESIGN DEPARTMENT

MATERIALS: RECONSTITUTED NATURAL MARBLE STONES, WHITE GRANITE OR GREY CONCRETE, WITH WOODEN BENCH.

FINISHING: SANDBLASTED.

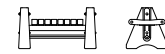

870
L: 1025 mm
D: 545 mm
H: 540 mm
W: 156 kg

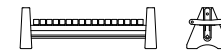

1650
L: 1805 mm
D: 545 mm
H: 540 mm
W: 186 kg



MATERIALI: DISPONIBILE IN AGGREGATO DI PIETRE DI MARMO NATURALI, GRANITO BIANCO O CEMENTO GRIGIO, CON SEDUTA IN LEGNO.

FINITURA: SABBIATURA.

PRECIOUS STONES /
PIETRE PREZIOSE



WHITE GRANITE /
GRANITO BIANCO



WOOD /
LEGNO





APOLLO /

BELLITALIA® DESIGN DEPARTMENT

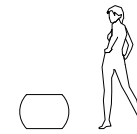

Ø: 650 mm
H: 450 mm
W: 307 kg

MATERIALS: RECONSTITUTED NATURAL MARBLE STONES OR WHITE GRANITE.

FINISHING: SANDBLASTED POLISHED OR BUSH HAMMERED.

MATERIALI: DISPONIBILE IN AGGREGATO DI PIETRE DI MARMO NATURALI O IN GRANITO BIANCO.

FINITURA: SABBIATURA, LEVIGATURA O BOCCIARDATURA.



PRECIOUS STONES /
PIETRE PREZIOSE



WHITE GRANITE /
GRANITO BIANCO



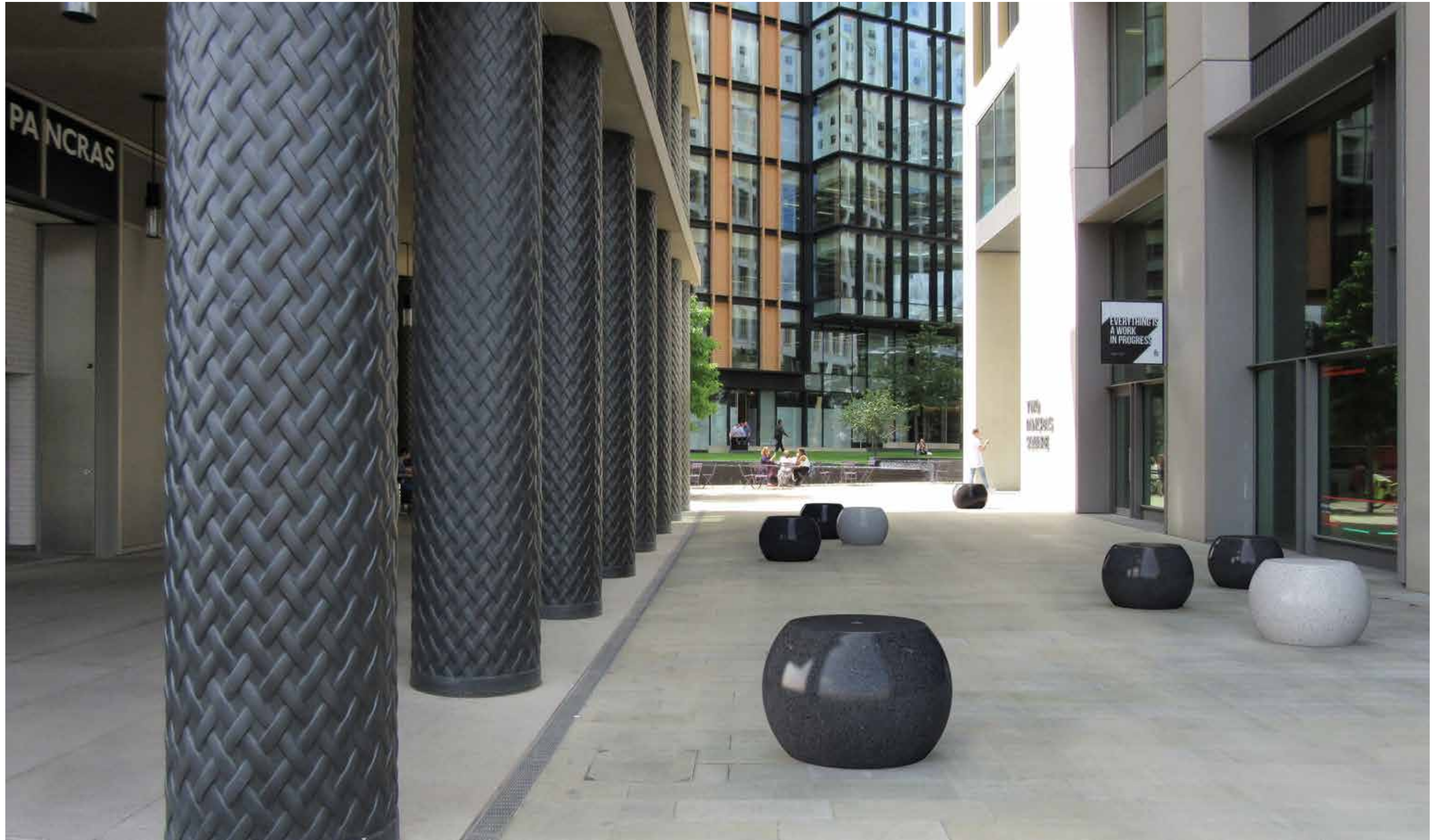



QUADRO /

BELLITALIA® DESIGN DEPARTMENT



L: 500 mm
W: 550 mm
H: 450 mm
W: 243 kg

MATERIALS: RECONSTITUTED NATURAL MARBLE STONES OR WHITE GRANITE.

FINISHING: SANDBLASTED WITH POLISHED OR BUSH HAMMERED SEAT SURFACE.

MATERIALI: DISPONIBILE IN AGGREGATO DI PIETRE DI MARMO NATURALI O IN GRANITO BIANCO.

FINITURA: LEVIGATURA O BOCCIARDATURA SUL PIANO DI SEDUTA.

PRECIOUS STONES /
PIETRE PREZIOSE



WHITE GRANITE /
GRANITO BIANCO





LABYRINTH /

BELLITALIA® DESIGN DEPARTMENT

MATERIALS: RECONSTITUTED NATURAL MARBLE STONES OR WHITE GRANITE.

FINISHING: SANDBLASTED WITH POLISHED OR BUSH HAMMERED SEAT SURFACE.

MATERIALI: DISPONIBILE IN AGGREGATO DI PIETRE DI MARMO NATURALI O IN GRANITO BIANCO.

FINITURA: LEVIGATURA O BOCCIARDATURA SUL PIANO DI SEDUTA.

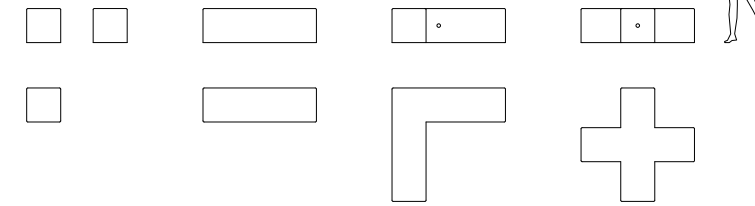
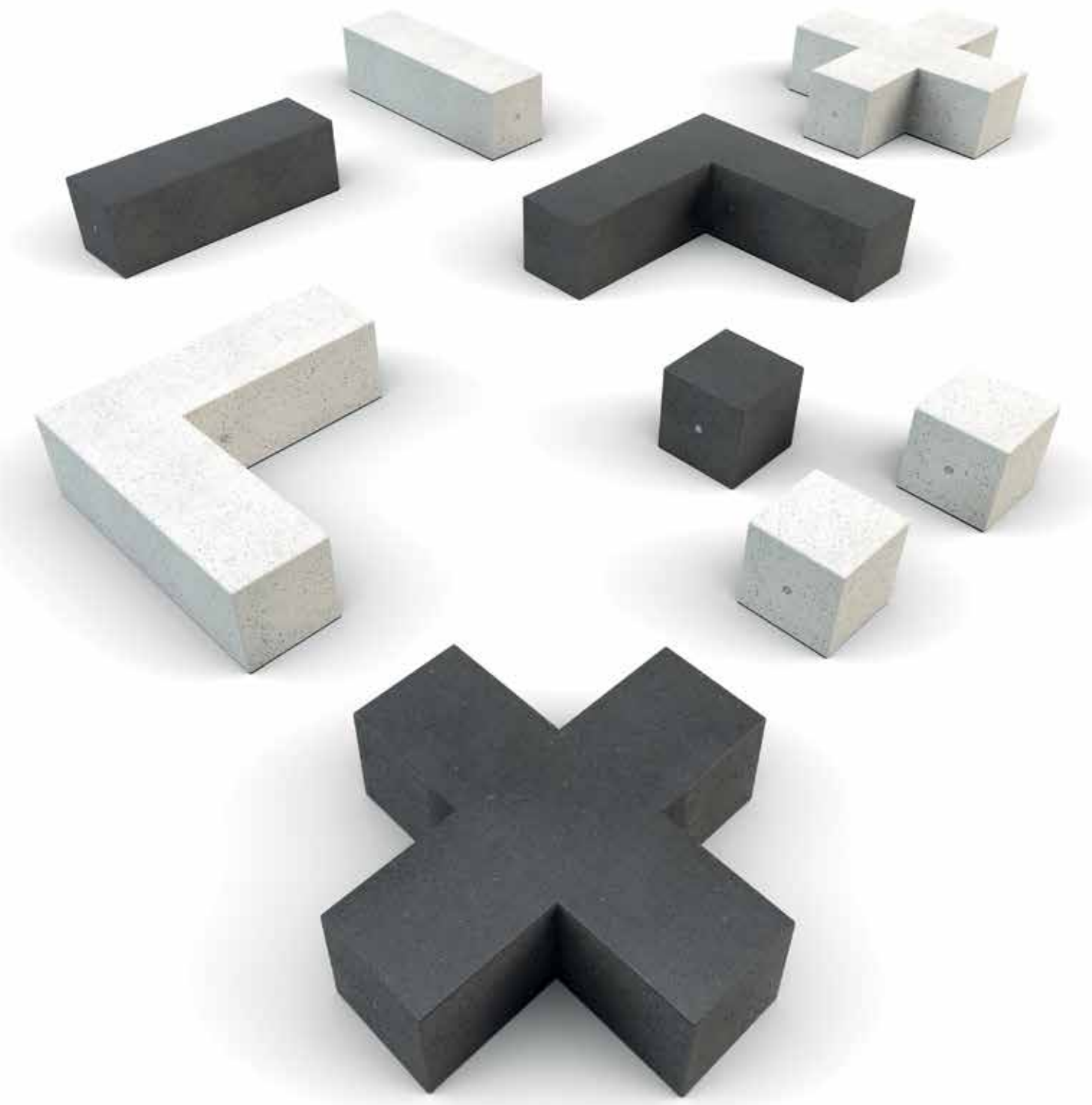

IDRA

L: 450 mm
D: 450 mm
H: 450 mm
W: 223 kg

ATE

L: 1500 mm
D: 450 mm
H: 450 mm
W: 744 kg

IRIS

L: 1500 mm
D: 1500 mm
H: 450 mm
W: 1264 kg

EOS

L: 1500 mm
D: 1500 mm
H: 450 mm
W: 1264 kg

PRECIOUS STONES /
PIETRE PREZIOSE



WHITE GRANITE /
GRANITO BIANCO



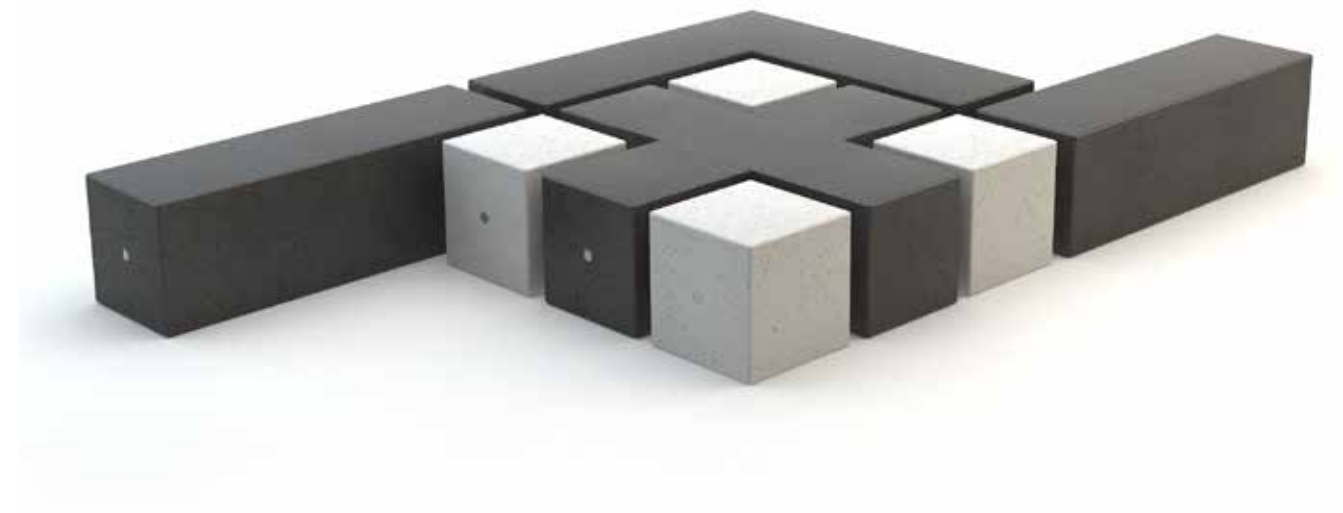





**Orione
Pegaso**
p. 452

Bios
p. 458

Atlante
p. 462

Crono
p. 466

Ermes
p. 468

Sorrento
p. 472

Città
p. 476

Urano
p. 482

**Plutone
Ashtray**
p. 40

LITTER BINS / CESTINI

ORIONE - PEGASO /

BELLITALIA® DESIGN DEPARTMENT

MATERIALS: RECONSTITUTED NATURAL MARBLE STONES OR WHITE GRANITE.

FINISHING: POLISHED OR BUSH HAMMERED.

ACCESSORIES: HOT GALVANIZED STEEL OR STAINLESS STEEL COVERING AND INTEGRATED ASHTRAY.

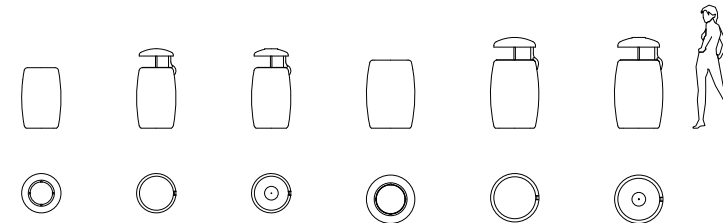

ORIONE

Ø: 520 mm
H: 800 / 1051 mm
W: 242 / 248 kg

PEGASO

Ø: 640 mm
H: 900 / 1200 mm
W: 347 / 383 kg

MATERIALI: DISPONIBILE IN AGGREGATO DI PIETRE DI MARMO NATURALI O IN GRANITO BIANCO.

FINITURA: LEVIGATURA O BOCCIARDATURA.

ACCESSORI: COPERTURA IN ACCIAIO ZINCATO O ACCIAIO INOX E POSACENERE INTEGRATO.

PRECIOUS STONES /
PIETRE PREZIOSE



WHITE GRANITE /
GRANITO BIANCO





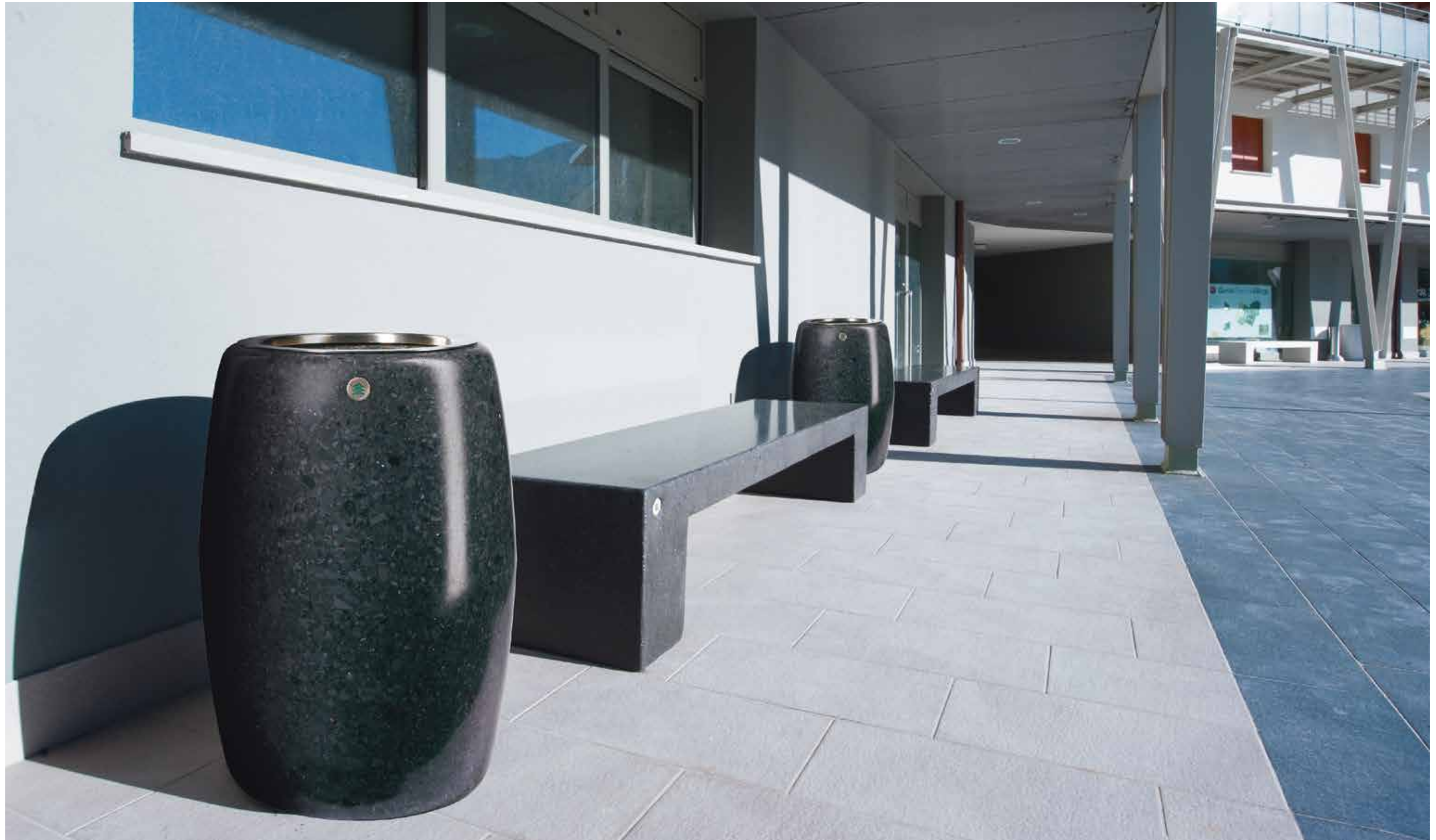

BIOS /

LUISA FONTANA

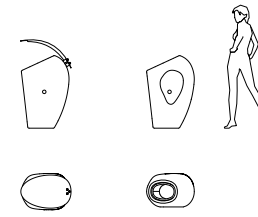

L: 665 mm L: 630 mm
 D: 460 mm D: 442 mm
 H: 1165 mm H: 960 mm
 W: 328 kg W: 318 kg

MATERIALS: RECONSTITUTED NATURAL MARBLE STONES OR WHITE GRANITE.

FINISHING: POLISHED OR FINE SANDBLASTED.

ACCESSORIES: STEEL OR STAINLESS STEEL COVERING, INTEGRATED ASHTRAY OR BAG HOLDER.

MATERIALI: DISPONIBILE IN AGGREGATO DI PIETRE DI MARMO NATURALI O IN GRANITO BIANCO.

FINITURA: LEVIGATURA O SABBIAATURA FINE.

ACCESSORI: COPERTURA IN ACCIAIO ZINCATO O ACCIAIO INOX, REGGI SACCO O POSACENERE IN ACCIAIO ZINCATO O ACCIAIO INOX.

PRECIOUS STONES /
 PIETRE PREZIOSE



WHITE GRANITE /
 GRANITO BIANCO





ATLANTE /

BELLITALIA® DESIGN DEPARTMENT



Ø: 674 mm
H: 1117 mm
W: 370 kg

MATERIALS: RECONSTITUTED NATURAL MARBLE STONES OR WHITE GRANITE.

FINISHING: POLISHED OR BUSH HAMMERED.

ACCESSORIES: HOT GALVANIZED STEEL OR STAINLESS STEEL COVERING.

MATERIALI: DISPONIBILE IN AGGREGATO DI PIETRE DI MARMO NATURALI O IN GRANITO BIANCO.

FINITURA: LEVIGATURA O BOCCIARDATURA.

ACCESSORI: COPERTURA IN ACCIAIO ZINCATO O ACCIAIO INOX.



PRECIOUS STONES /
PIETRE PREZIOSE

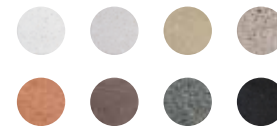

WHITE GRANITE /
GRANITO BIANCO





CRONO /

BELLITALIA® DESIGN DEPARTMENT

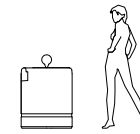

Ø: 674 mm
H: 970 mm
W: 355 kg

MATERIALS: RECONSTITUTED NATURAL MARBLE STONES OR WHITE GRANITE, WITH STAINLESS STEEL ASHTRAY.
FINISHING: POLISHED OR BUSH HAMMERED.
ACCESSORIES: NAMEPLATE AND ALLUMINIUM BAND.

MATERIALI: DISPONIBILE IN AGGREGATO DI PIETRE DI MARMO NATURALI O IN GRANITO BIANCO, CON BACINELLA POSACENERE IN ACCIAIO INOX.
FINITURA: LEVIGATURA O BOCCIARDATURA.
ACCESSORI: TARGHETTA ILLUSTRATIVA E FASCETTA IN ALLUMINIO.



PRECIOUS STONES /
PIETRE PREZIOSE

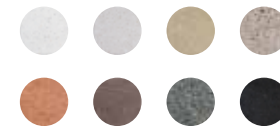

WHITE GRANITE /
GRANITO BIANCO



ERMES /

BELLITALIA® DESIGN DEPARTMENT

MATERIALS: RECONSTITUTED NATURAL MARBLE STONES OR WHITE GRANITE.

FINISHING: POLISHED OR BUSH HAMMERED.

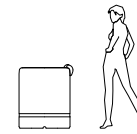

Ø: 674 mm
H: 842 mm
W: 360 kg

MATERIALI: DISPONIBILE IN AGGREGATO DI PIETRE DI MARMO NATURALI O IN GRANITO BIANCO.

FINITURA: LEVIGATURA O BOCCIARDATURA.

PRECIOUS STONES /
PIETRE PREZIOSE

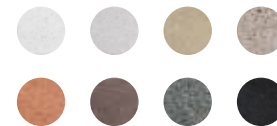

WHITE GRANITE /
GRANITO BIANCO





SORRENTO /

BELLITALIA® DESIGN DEPARTMENT

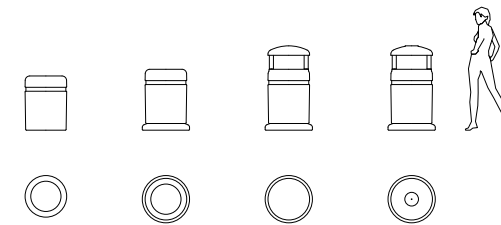

Ø: 550 mm
H: 717 mm
W: 210 kg

Ø: 625 mm
H: 1115 mm
W: 287 kg

MATERIALS: RECONSTITUTED NATURAL MARBLE STONES, WHITE GRANITE OR GREY CONCRETE.

FINISHING: SANDBLASTED.

ACCESSORIES: COPPER OR STAINLESS STEEL BAND, STEEL COVERING WITH OPTIONAL INTEGRATED ASHTRAY, LARGE ASHTRAY. PROVIDED WITH LEVELLING SYSTEM.

MATERIALI: DISPONIBILE IN AGGREGATO DI PIETRE DI MARMO NATURALI, GRANITO BIANCO O CEMENTO GRIGIO.

FINITURA: SABBIATURA.

ACCESSORI: FASCIA IN RAME O INOX, COPERTURA IN ACCIAIO CON EVENTUALE POSACENERE, VASSOIO USO POSACENERE. CON LIVELLAMENTO.

PRECIOUS STONES /
PIETRE PREZIOSE



WHITE GRANITE /
GRANITO BIANCO





CITTA' /

BELLITALIA® DESIGN DEPARTMENT

MATERIALS: RECONSTITUTED NATURAL MARBLE STONES OR WHITE GRANITE.
FINISHING: SANDBLASTED.
ACCESSORIES: COPPER OR STAINLESS STEEL BAND.

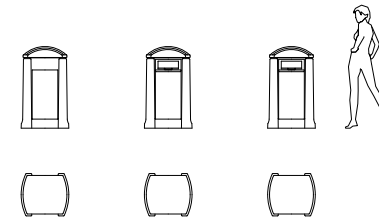

L: 630 mm
 D: 560 mm
 H: 1080 mm
 W: 335 kg

MATERIALI: DISPONIBILE IN AGGREGATO DI PIETRE DI MARMO NATURALI O IN GRANITO BIANCO.
FINITURA: SABBIATURA.
ACCESSORI: FASCETTA IN RAME O INOX.



PRECIOUS STONES /
 PIETRE PREZIOSE



WHITE GRANITE /
 GRANITO BIANCO







URANO /

BELLITALIA® DESIGN DEPARTMENT

MATERIALS: RECONSTITUTED NATURAL MARBLE STONES OR WHITE GRANITE, WITH STEEL PANELS AND COVERING.
FINISHING: SANDBLASTED.

MATERIALI: DISPONIBILE IN AGGREGATO DI PIETRE DI MARMO NATURALI O IN GRANITO BIANCO, CON PANNELLI E COPERTURA IN ACCIAIO.
FINITURA: SABBIATURA.

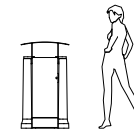

L: 630 mm
 D: 600 mm
 H: 1140 mm
 W: 306 kg

PRECIOUS STONES /
 PIETRE PREZIOSE



WHITE GRANITE /
 GRANITO BIANCO





PLUTONE ASHTRAY /

BELLITALIA® DESIGN DEPARTMENT

MATERIALS: RECONSTITUTED NATURAL MARBLE STONES OR WHITE GRANITE, WITH STAINLESS STEEL ASHTRAY.
FINISHING: POLISHED OR BUSH HAMMERED.

MATERIALI: DISPONIBILE IN AGGREGATO DI PIETRE DI MARMO NATURALI O IN GRANITO BIANCO, CON POSACENERE IN ACCIAIO INOX.

FINITURA: LEVIGATURA O BOCCIARDATURA.



Ø: 400 mm
 H: 685 mm
 W: 168 kg

PRECIOUS STONES /
 PIETRE PREZIOSE



WHITE GRANITE /
 GRANITO BIANCO







Orchidea
p. 494

Quadrifoglio
p. 496

Girasole
p. 498

Asola
p. 502

Margherita
p. 504

Calla
p. 508

FOUNTAINS / FONTANE

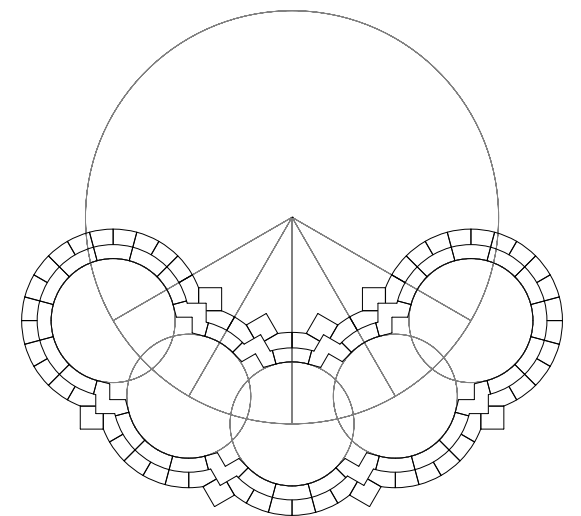
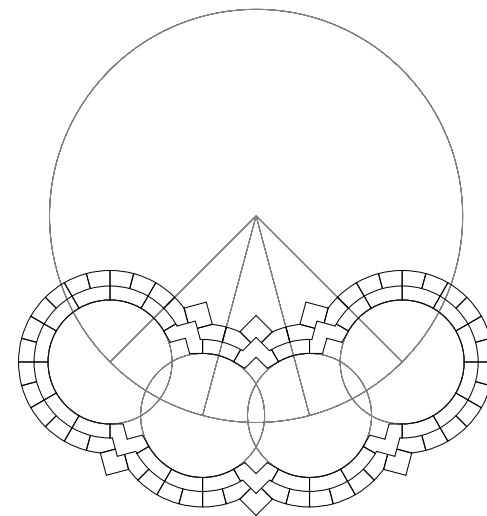
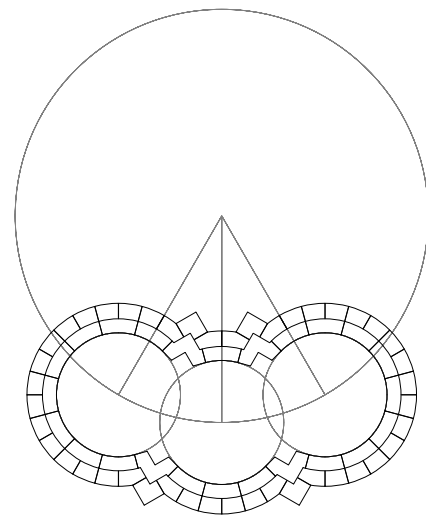
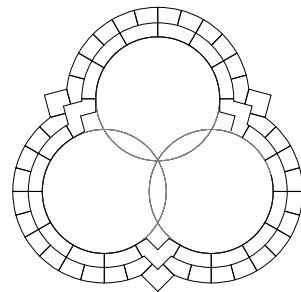
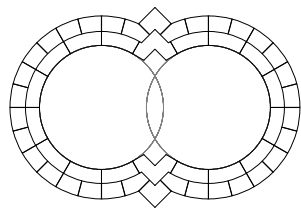
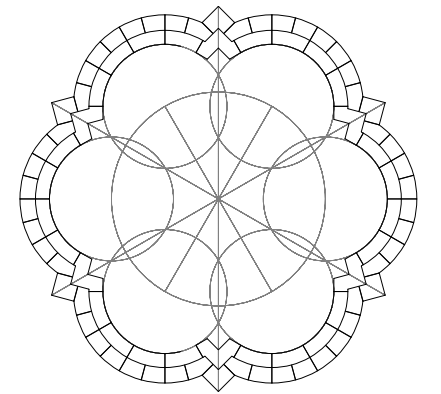
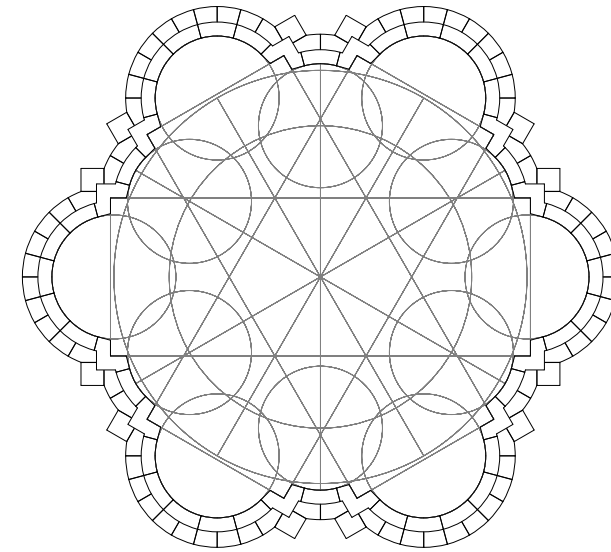
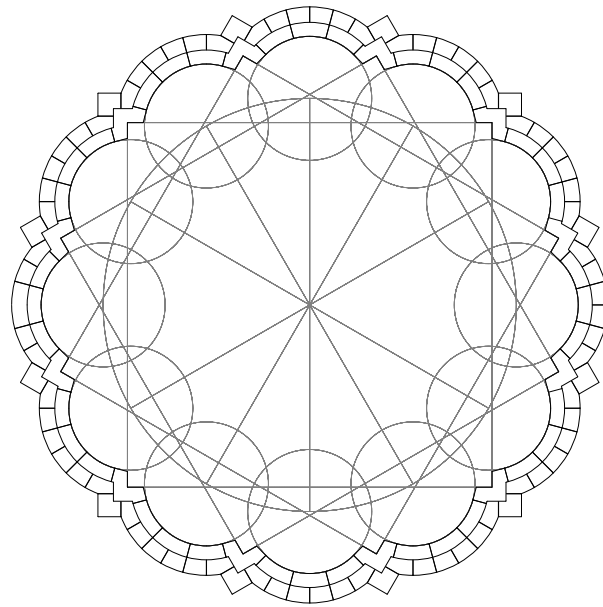
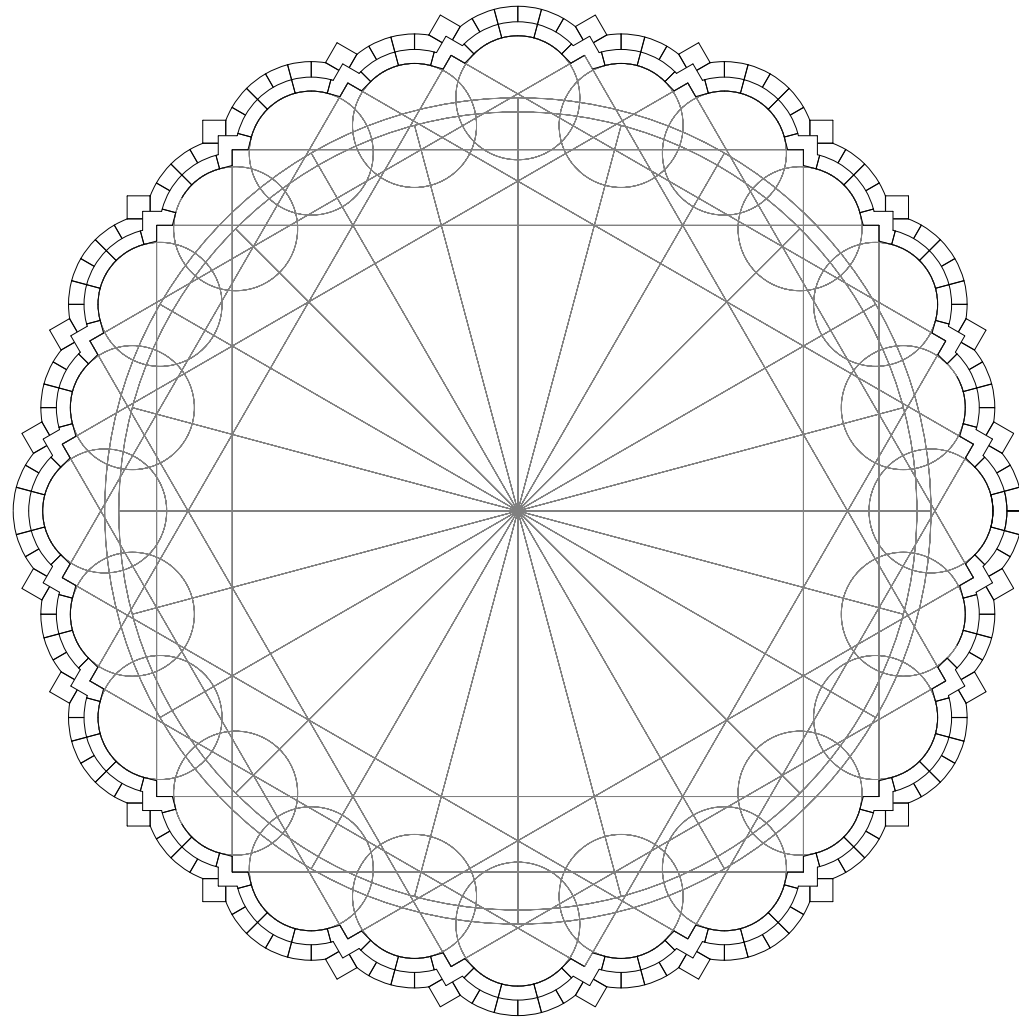



ORCHIDEA /

BELLITALIA® DESIGN DEPARTMENT

MATERIALS: RECONSTITUTED NATURAL MARBLE STONES OR WHITE GRANITE.
FINISHING: POLISHED.
ACCESSORIES: SANDBLASTED PERIMETRAL PLATES.



PIASTRA CURVA PIASTRA AD ANGOLO CONCIO A CURVA CONCIO A PUNTA

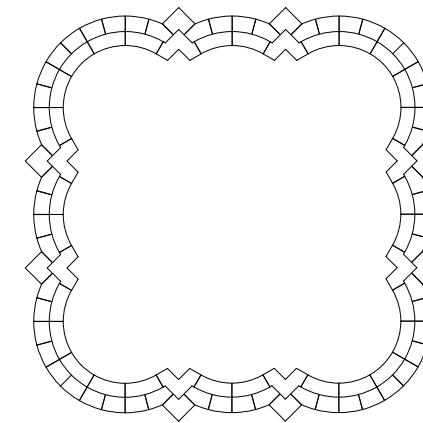

L: 12840 mm
W: 12840
H: 500 mm
W: 18060 kg

MATERIALI: DISPONIBILE IN AGGREGATO DI PIETRE DI MARMO NATURALI O IN GRANITO BIANCO.
FINITURA: LEVIGATURA.
ACCESSORI: PIASTRE PERIMETRALI SABBIATE.

PRECIOUS STONES /
PIETRE PREZIOSE



WHITE GRANITE /
GRANITO BIANCO



QUADRIFOGLIO /

BELLITALIA® DESIGN DEPARTMENT

MATERIALS: RECONSTITUTED NATURAL MARBLE STONES OR WHITE GRANITE.

FINISHING: POLISHED.

ACCESSORIES: SANDBLASTED PERIMETRAL PLATES.

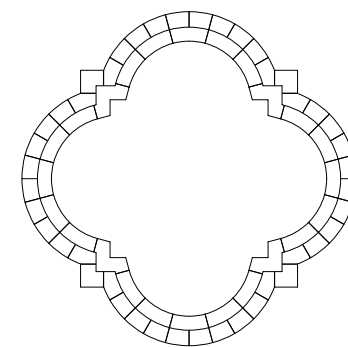

L: 8840 mm
W: 8840 mm
H: 500 mm
W: 11576 kg

PRECIOUS STONES /
PIETRE PREZIOSE

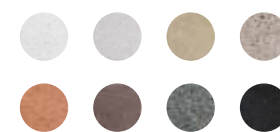

WHITE GRANITE /
GRANITO BIANCO



GIRASOLE /

BELLITALIA® DESIGN DEPARTMENT

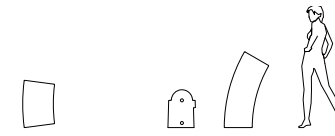

PIASTRA
CURVA

CONCIO A
CURVA

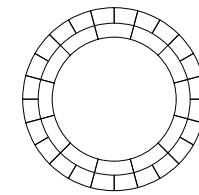

Ø: 4840 mm
H: 500 mm
W: 5568 kg

MATERIALS: RECONSTITUTED NATURAL MARBLE STONES OR WHITE GRANITE.

FINISHING: POLISHED.

ACCESSORIES: SANDBLASTED PERIMETRAL PLATES.

MATERIALI: DISPONIBILE IN AGGREGATO DI PIETRE DI MARMO NATURALI O IN GRANITO BIANCO.

FINITURA: LEVIGATURA.

ACCESSORI: PIASTRE PERIMETRALI SABBIATE.

PRECIOUS STONES /
PIETRE PREZIOSE



WHITE GRANITE /
GRANITO BIANCO





ASOLA /

BELLITALIA® DESIGN DEPARTMENT

MATERIALS: RECONSTITUTED NATURAL MARBLE STONES OR WHITE GRANITE.

FINISHING: POLISHED.

ACCESSORIES: SANDBLASTED PERIMETRAL PLATES.

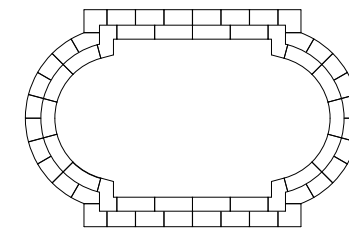

L: 8840 mm
W: 5740 mm
H: 500 mm
W: 11283 kg

MATERIALI: DISPONIBILE IN AGGREGATO DI PIETRE DI MARMO NATURALI O IN GRANITO BIANCO.

FINITURA: LEVIGATURA.

ACCESSORI: PIASTRE PERIMETRALI SABBIATE.

PRECIOUS STONES /
PIETRE PREZIOSE

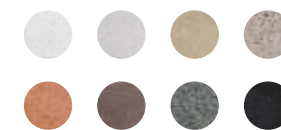

WHITE GRANITE /
GRANITO BIANCO



MARGHERITA /

BELLITALIA® DESIGN DEPARTMENT

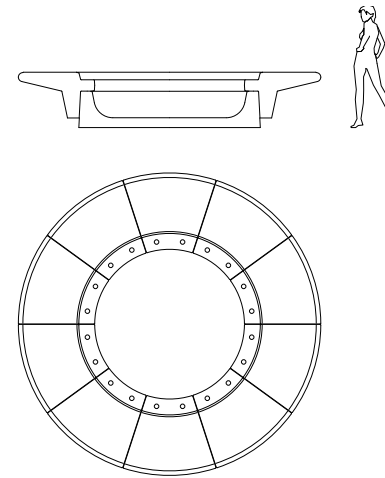

Ø: 4000 mm
H: 500 mm
W: 8337 kg

MATERIALS: RECONSTITUTED NATURAL MARBLE STONES OR WHITE GRANITE.

FINISHING: SANDBLASTED WITH POLISHED OR BUSH HAMMERED SEAT SURFACE.

ACCESSORIES: SANDBLASTED PERIMETRAL PLATES.

MATERIALI: DISPONIBILE IN AGGREGATO DI PIETRE DI MARMO NATURALI O IN GRANITO BIANCO.

FINITURA: SABBIATURA CON PIANO DI SEDUTA LEVIGATO O BOCCIARDATO.

ACCESSORI: PIASTRE PERIMETRALI SABBIATE.

PRECIOUS STONES /
PIETRE PREZIOSE

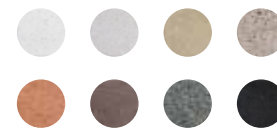

WHITE GRANITE /
GRANITO BIANCO





CALLA /

BELLITALIA® DESIGN DEPARTMENT

MATERIALS: RECONSTITUTED NATURAL MARBLE STONES OR WHITE GRANITE.

FINISHING: SANDBLASTING.

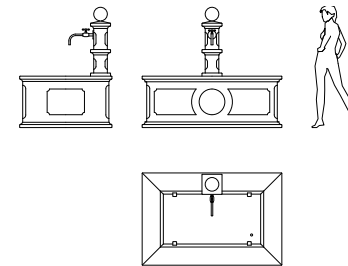

L: 1847 mm
W: 1220 mm
H: 1591 mm
W: 2000 kg

MATERIALI: DISPONIBILE IN AGGREGATO DI PIETRE DI MARMO NATURALI O IN GRANITO BIANCO.

FINITURA: SABBIATURA.

PRECIOUS STONES /
PIETRE PREZIOSE

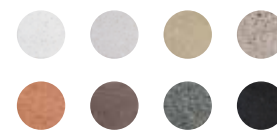

WHITE GRANITE /
GRANITO BIANCO







Sfera
p. 514

Titano
p. 520

Plutone
p. 522

Ground
p. 526

Vertical
p. 530

BOLLARDS / DISSUASORI

SFERA /

BELLITALIA® DESIGN DEPARTMENT

MATERIALS: RECONSTITUTED NATURAL MARBLE STONES OR WHITE GRANITE.

FINISHING: POLISHED OR BUSH HAMMERED.

MATERIALI: DISPONIBILE IN AGGREGATO DI PIETRE DI MARMO NATURALI O IN GRANITO BIANCO.

FINITURA: LEVIGATURA O BOCCIARDATURA.

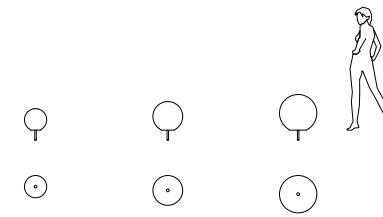

Ø: 300 mm Ø: 400 mm Ø: 500 mm
 H: 283 mm H: 377 mm H: 471 mm
 W: 37 kg W: 83 kg W: 161 kg



PRECIOUS STONES /
 PIETRE PREZIOSE



WHITE GRANITE /
 GRANITO BIANCO









TITANO /

BELLITALIA® DESIGN DEPARTMENT

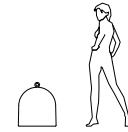

Ø: 500 mm
H: 579 mm
W: 200 kg

MATERIALS: RECONSTITUTED NATURAL MARBLE STONES, WHITE GRANITE OR GREY CONCRETE.

FINISHING: SANDBLASTED, POLISHED OR BUSH HAMMERED.

MATERIALI: DISPONIBILE IN AGGREGATO DI PIETRE DI MARMO NATURALI, GRANITO BIANCO O CEMENTO GRIGIO.

FINITURA: SABBIAIATURA, LEVIGATURA O BOCCIARDATURA.

PRECIOUS STONES /
PIETRE PREZIOSE



WHITE GRANITE /
GRANITO BIANCO





PLUTONE /

BELLITALIA® DESIGN DEPARTMENT



Ø: 400 mm
H: 704 mm
W: 165 kg

MATERIALS: RECONSTITUTED NATURAL MARBLE STONES OR WHITE GRANITE.

FINISHING: POLISHED OR BUSH HAMMERED.

MATERIALI: DISPONIBILE IN AGGREGATO DI PIETRE DI MARMO NATURALI O IN GRANITO BIANCO.

FINITURA: LEVIGATURA O BOCCIARDATURA.

PRECIOUS STONES /
PIETRE PREZIOSE

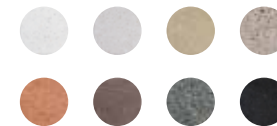

WHITE GRANITE /
GRANITO BIANCO





GROUND /

BELLITALIA® DESIGN DEPARTMENT

MATERIALS: RECONSTITUTED NATURAL MARBLE STONE, WHITE GRANITE OR FREY CONCRETE.

FINISHING: SANDBLASTED.

ACCESSORIES: STEEL EYEBOLT.

MATERIALI: DISPONIBILE IN AGGREGATO DI PIETRE DI MARMO NATURALI O IN GRANITO BIANCO O IN CEMENTO GRIGIO.

FINITURA: SABBIAIATURA.
ACCESSORI: GOLFARE IN ACCIAIO.

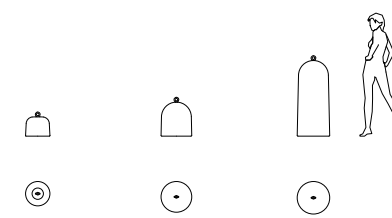

KID	TIP	IKI
Ø: 322 mm	Ø: 406 mm	Ø: 430 mm
H: 319 mm	H: 514 mm	H: 1064 mm
W: 46 kg	W: 116 kg	W: 300 kg

PRECIOUS STONES /
PIETRE PREZIOSE



WHITE GRANITE /
GRANITO BIANCO





VERTICAL /

BELLITALIA® DESIGN DEPARTMENT

MATERIALS: RECONSTITUTED NATURAL MARBLE STONE, WHITE GRANITE OR FREY CONCRETE.

FINISHING: SANDBLASTED.

ACCESSORIES: STEEL EYEBOLT.

MATERIALI: DISPONIBILE IN AGGREGATO DI PIETRE DI MARMO NATURALI O IN GRANITO BIANCO O IN CEMENTO GRIGIO.

FINITURA: SABBIAIATURA.
ACCESSORI: GOLFARE IN ACCIAIO.

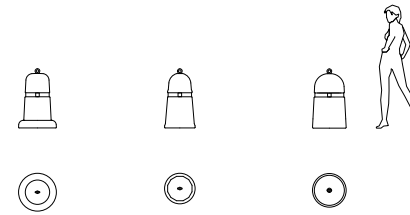

RAY

Ø: 500 mm
H: 784 mm
W: 200 kg

ARO

Ø: 404 mm
H: 783 mm
W: 182 kg

MEL

Ø: 445 mm
H: 784 mm
W: 210 kg

PRECIOUS STONES /
PIETRE PREZIOSE



WHITE GRANITE /
GRANITO BIANCO







Luna - Venere
Combiata
p. 536

Ø 820
Combiata
p. 538

Ø 820 W
Combiata
p. 540

Ø 1220
Combiata
p. 542

Ø 1220 W
Combiata
p. 544

Ø 1620 W
Combiata
p. 546

COMBINATIONS / COMBINAZIONI

LUNA - VENERE

COMBINATA /

BELLITALIA® DESIGN DEPARTMENT

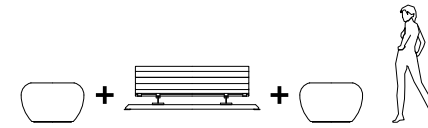

CARINA BENCH + LUNA - VENERE /
PANCA CARINA + LUNA



ZEBRA BENCH + LUNA - VENERE /
PANCA ZEBRA + LUNA



ZEBRA DUETTO BENCH - VENERE /
PANCA ZEBRA DUETTO + LUNA

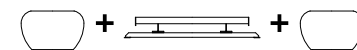

ZEBRA SEDILE BENCH - VENERE /
PANCA ZEBRA SEDILE + LUNA

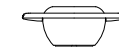

SATURNIA BENCH - VENERE /
PANCA SATURNIA + LUNA

L: 3380 / 3983 mm
W: 830 / 1153 mm
H: 739 mm

MATERIALS: RECONSTITUTED NATURAL MARBLE STONES OR WHITE GRANITE.

FINISHING: POLISHED OR BUSH HAMMERED.

ACCESSORIES: STEEL OR STAINLESS STEEL BENCH, FLAT OR WITH BACKREST.

MATERIALI: DISPONIBILE IN AGGREGATO DI PIETRE DI MARMO NATURALI O IN GRANITO BIANCO.

FINITURA: LEVIGATURA O BOCCIARDATURA.

ACCESSORI: PANCA IN LEGNO, IN ACCIAIO O IN ACCIAIO INOX, PIANA O CON SCHIENALE.

PRECIOUS STONES /
PIETRE PREZIOSE

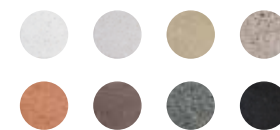

WHITE GRANITE /
GRANITO BIANCO



WOOD /
LEGNO



Ø 820 COMBINATA / BELLITALIA® DESIGN DEPARTMENT



ZEBRA BENCH + TIMELESS
Ø820 / PANCA ZEBRA + TIMELESS
Ø820



**PANCA ZEBRA DUETTO +
TIMELESS Ø820** / PANCA ZEBRA
DUETTO + TIMELESS Ø820



**ZEBRA SEDILE BENCH +
TIMELESS Ø820** / PANCA ZEBRA
SEDILE + TIMELESS Ø820

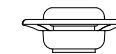

SATURNIA BENCH + TIMELESS
Ø820 / PANCA SATURNIA +
TIMELESS Ø820

L: 3320 mm
W: 820 mm
H: 731 mm

MATERIALS: RECONSTITUTED NATURAL MARBLE STONES, WHITE GRANITE OR GREY CONCRETE.

FINISHING: POLISHED, BUSH HAMMERED OR SANDBLASTED.

ACCESSORIES: STEEL OR STAINLESS STEEL BENCH, FLAT OR WITH BACKREST.

MATERIALI: DISPONIBILE IN AGGREGATO DI PIETRE DI MARMO NATURALI, GRANITO BIANCO O CEMENTO GRIGIO.

FINITURA: LEVIGATURA, BOCCIARDATURA O SABBIATURA.

ACCESSORI: FASCIA IN RAME O FASCIA IN INOX. CON LIVELLAMENTO. PANCA IN ACCIAIO O IN ACCIAIO INOX, PIANA O CON SCHIENALE.

PRECIOUS STONES /
PIETRE PREZIOSE



WHITE GRANITE /
GRANITO BIANCO



WOOD /
LEGNO



Ø 820 W COMBINATA /

BELLITALIA® DESIGN DEPARTMENT

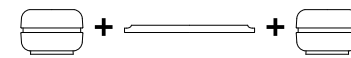

PONTE BENCH (WOOD) + TIMELESS Ø820 / PANCA PONTE IN LEGNO + TIMELESS Ø820



PONTE BENCH CON SCHIENALE (WOOD) + TIMELESS Ø820 / PANCA PONTE IN LEGNO CON SCHIENALE + TIMELESS Ø820

MATERIALS: RECONSTITUTED NATURAL MARBLE STONES, WHITE GRANITE OR GREY CONCRETE.

FINISHING: POLISHED, BUSH HAMMERED OR SANDBLASTED.

ACCESSORIES: STEEL OR STAINLESS STEEL BENCH, FLAT OR WITH BACKREST.

MATERIALI: DISPONIBILE IN AGGREGATO DI PIETRE DI MARMO NATURALI, GRANITO BIANCO O CEMENTO GRIGIO.

FINITURA: LEVIGATURA, BOCCIARDATURA O SABBIATURA.

ACCESSORI: FASCIA IN RAME O FASCIA IN INOX. CON LIVELLAMENTO. PANCA IN LEGNO, PIANA O CON SCHIENALE.

PRECIOUS STONES /
PIETRE PREZIOSE



WHITE GRANITE /
GRANITO BIANCO



WOOD /
LEGNO



Ø 1220 COMBINATA /

BELLITALIA® DESIGN DEPARTMENT



ZEBRA BENCH + TIMELESS
Ø1220 / PANCA ZEBRA +
TIMELESS Ø1220



PANCA ZEBRA DUETTO +
TIMELESS Ø1220 / PANCA ZEBRA
DUETTO + TIMELESS Ø1220



ZEBRA SEDILE BENCH +
TIMELESS Ø1220 / PANCA ZEBRA
SEDILE + TIMELESS Ø1220

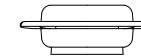

SATURNIA BENCH + TIMELESS
Ø1220 / PANCA SATURNIA +
TIMELESS Ø1220

MATERIALS: RECONSTITUTED
NATURAL MARBLE STONES,
WHITE GRANITE OR GREY
CONCRETE.

FINISHING: POLISHED,
BUSH HAMMERED OR
SANDBLASTED.

ACCESSORIES: STEEL OR
STAINLESS STEEL BENCH,
FLAT OR WITH BACKREST.

MATERIALI: DISPONIBILE IN
AGGREGATO DI PIETRE DI
MARMO NATURALI, GRANITO
BIANCO O CEMENTO GRIGIO.

FINITURA: LEVIGATURA,
BOCCIARDATURA O
SABBIATURA.

ACCESSORI: FASCIA IN
RAME O FASCIA IN INOX. CON
LIVELLAMENTO. PANCA IN
ACCIAIO O IN ACCIAIO INOX,
PIANA O CON SCHIENALE.

PRECIOUS STONES /
PIETRE PREZIOSE

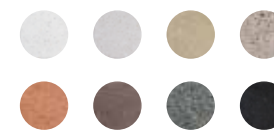

WHITE GRANITE /
GRANITO BIANCO



WOOD /
LEGNO



Ø 1220 W COMBINATA /

BELLITALIA® DESIGN DEPARTMENT

MATERIALS: RECONSTITUTED NATURAL MARBLE STONES, WHITE GRANITE OR GREY CONCRETE.

FINISHING: POLISHED, BUSH HAMMERED OR SANDBLASTED.

ACCESSORIES: STEEL OR STAINLESS STEEL BENCH, FLAT OR WITH BACKREST.

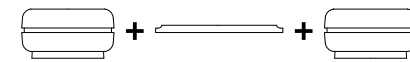

PONTE BENCH (WOOD) + TIMELESS Ø1220 / PANCA PONTE IN LEGNO + TIMELESS Ø1220



PONTE BENCH CON SCHIENALE (WOOD) + TIMELESS Ø1220 / PANCA PONTE IN LEGNO CON SCHIENALE + TIMELESS Ø1220

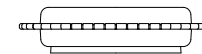

BENCH (WOOD) + TIMELESS Ø1220 / PANCA CIRCOLARE IN LEGNO + TIMELESS Ø1220

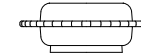

MATERIALI: DISPONIBILE IN AGGREGATO DI PIETRE DI MARMO NATURALI, GRANITO BIANCO O CEMENTO GRIGIO.

FINITURA: LEVIGATURA, BOCCIARDATURA O SABBIATURA.

ACCESSORI: FASCIA IN RAME O FASCIA IN INOX. CON LIVELLAMENTO. PANCA IN LEGNO, PIANA O CON SCHIENALE.

PRECIOUS STONES /
PIETRE PREZIOSE

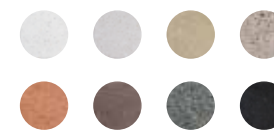

WHITE GRANITE /
GRANITO BIANCO



WOOD /
LEGNO





Ø 1620 W COMBINATA / BELLITALIA® DESIGN DEPARTMENT



PONTE BENCH (WOOD) + TIMELESS Ø1620 / PANCA
PONTE IN LEGNO + TIMELESS Ø1620



PONTE BENCH CON SCHIENALE (WOOD) + TIMELESS Ø1620 / PANCA
PONTE IN LEGNO CON SCHIENALE + TIMELESS Ø1620

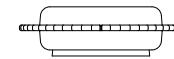

BENCH (WOOD) + TIMELESS Ø1620 / PANCA CIRCOLARE IN LEGNO + TIMELESS Ø1620

MATERIALS: RECONSTITUTED NATURAL MARBLE STONES, WHITE GRANITE OR GREY CONCRETE.

FINISHING: POLISHED, BUSH HAMMERED OR SANDBLASTED.

ACCESSORIES: COPPER OR STAINLESS STEEL BAND. PROVIDED WITH LEVELLING SYSTEM. BENCH IN WOOD, FLAT OR WITH BACKREST.

MATERIALI: DISPONIBILE IN AGGREGATO DI PIETRE DI MARMO NATURALI, GRANITO BIANCO O CEMENTO GRIGIO. **FINITURA:** LEVIGATURA, BOCCIARDATURA O SABBIATURA.

ACCESSORI: FASCIA IN RAME O FASCIA IN INOX. CON LIVELLAMENTO. PANCA IN LEGNO, PIANA O CON SCHIENALE.

PRECIOUS STONES /
PIETRE PREZIOSE

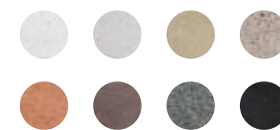

WHITE GRANITE /
GRANITO BIANCO



WOOD /
LEGNO





ORGANIC /
SCULTURE

ORGANIC / SCULTURE

THE CREATION OF THE ORGANIC LINE CAME FROM THE GENIUS OF THE CZECH ARTIST MATOUŠ HOLÝ, WHO USED AN ORGANIC MATERIAL SUCH AS SOIL TO GIVE SHAPE TO THE IDEA OF LIVING URBAN FURNISHINGS AND DYNAMIC LINES, WHICH ARE ABLE TO INTEGRATE INTO ANY ENVIRONMENT HARMONIOUSLY. THE ACRYLIC-POLYURETHANE VARNISH USED FOR FINISHING, THE SAME AS USED IN THE AUTOMOTIVE INDUSTRY, GUARANTEES THE DURABILITY OF THE PIGMENTATION AND GIVES AN ORIGINAL ELEGANCE.

THROUGHOUT THE PRODUCTS OF THE ORGANIC LINE, ART MEETS FUNCTION: THE SEATS SEEM TO WANT TO ADAPT TO ANY REST POSITION, WHILE OFFERING THE EXPERIENCE OF SINUOUS FORMS.

THE THREE-DIMENSIONALITY AND THE SUPPLENESS CREATE A VISUALLY IMPRESSIVE EFFECT.

THE PRODUCTS OF THE ORGANIC LINE ARE DESIGNED USING CUTTING-EDGE SOFTWARE MADE FOR THE DESIGN OF STREET FURNITURE AND 3D MODELLING, WITH INERT MATERIALS FROM LOCAL SUPPLIERS AND CAST INTO RESIN MOULDS.

AFTER PERFECTING IN THE MOULD, THE SURFACE UNDERGOES A DOUBLE FINISH: THE FIRST WITH A LAYER OF EPOXY VARNISH IN A CHOICE OF COLOURS (FIRE RED RAL 3000, JET BLACK RAL 9005 OR INTENSE PURE WHITE RAL 9010) AND THE SECOND WITH AN ACRYLIC-POLYURETHANE VARNISH, THE SAME AS THOSE USED IN THE AUTOMOTIVE INDUSTRY. ALL ITEMS ARE ALSO AVAILABLE IN WHITE GRANITE PAINTED WITH ANTI-DECAY COATINGS; IN THIS CASE THE SEATING SURFACES NATURALLY SMOOTH, WHILE THE LATERAL SURFACES ARE FINELY BUSH HAMMERED.

ALL PRODUCTS ARE PROVIDED WITH FASTENING POINTS BY MEANS OF STEEL THREADED BUSHES, FOR THE USE OF ROPE DOCKING SYSTEMS; THESE ARE THEN COVERED WITH **BELLITALIA®** ALUMINUM PLATES.



LE CREAZIONI DELLA LINEA ORGANIC NASCONO DAL GENIO DELL'ARTISTA CECO MATOUŠ HOLÝ, CHE HA USATO UN MATERIALE ORGANICO COME LA TERRA, PER DARE FORMA ALL'IDEA DI UN ARREDO URBANO VIVENTE, DALLE LINEE DINAMICHE, CAPACE DI INTEGRARSI IN QUALSIASI CONTESTO IN MODO ARMONICO. LE VERNICI ACRIL-POLIURETANICHE UTILIZZATE PER LA FINITURA, LE STESSE USATE PER L'INDUSTRIA AUTOMOBILISTICA, GARANTISCONO LA DURATA DELLA PIGMENTAZIONE E UN'ORIGINALE ELEGANZA.

NEI PRODOTTI DELLA LINEA ORGANIC L'ARTE INCONTRA LA FUNZIONALITÀ: LE SEDUTE SEMBRANO VOLERSI ADATTARE A QUALUNQUE POSIZIONE DI RIPOSO, OFFRENDO AL CONTEMPO LA SPERIMENTAZIONE DI FORME SINUOSE.

LA TRIDIMENSIONALITÀ E LA FLESSUOSITÀ CREANO UN IMPATTO VISIVO DI GRANDE EFFETTO.

GLI ARTICOLI DELLA LINEA ORGANIC VENGONO PROGETTATI UTILIZZANDO UN SOFTWARE ALL'AVANGUARDIA PER IL DESIGN DELL'ARREDO URBANO E LA MODELLAZIONE 3D, PRODOTTI CON INERTI PROVENIENTI DA FORNITORI LOCALI E GETTATI IN STAMPI DI RESINA.

DOPO LA MATURAZIONE IN STAMPO, LA SUPERFICIE SUBISCE UNA DOPPIA FINITURA: LA PRIMA CON UNO STRATO DI VERNICE EPOSSIDICA A SCELTA TRA I COLORI ROSSO FUOCO RAL 3000, NERO INTENSO RAL 9005 O BIANCO PURO RAL 9010 E LA SECONDA CON VERNICI ACRIL-POLIURETANICHE DELLO STESSO TIPO DI QUELLE USATE PER L'AUTOMOTIVE. TUTTI GLI ARTICOLI SONO ANCHE DISPONIBILI NELLA VERSIONE IN GRANITO BIANCO VERNICIATO ANTIDEGRADO; IN QUESTO CASO LE SUPERFICI DI SEDUTA SONO FINITE LISCO NATURALE MENTRE QUELLE LATERALI SONO BOCCIARDATE FINEMENTE.

TUTTI I PRODOTTI SONO DOTATI DI PUNTI DI VINCOLO TRAMITE BOCCOLE FILETTATE IN ACCIAIO OVE INTRODURRE I SISTEMI DI AGGANCIO DELLE FUNI; GLI STESSI VENGONO POI COPERTI CON TARGHETTE **BELLITALIA®** IN ALLUMINIO.





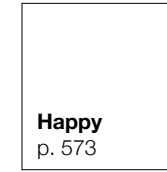
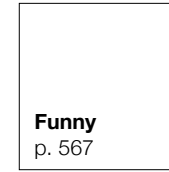
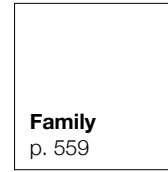
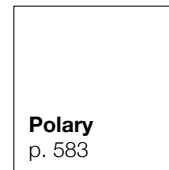
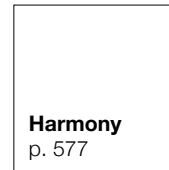
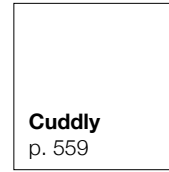

BENCHES / PANCHINE

LITTER BINS / CESTINI

CUDDLY + FAMILY /

MATOUŠ HOLÝ

MATERIALS: WHITE GRANITE OR GLOSSY CONCRETE.
FINISHING: VARNISHED WITH ACRYLIC POLYURETHANE PAINT ANTI UV.

MATERIALI: GRANITO BIANCO O CEMENTO GLOSSY.
FINITURA: VERNICIATURA ACRIL-POLIURETANICA ANTI UV.

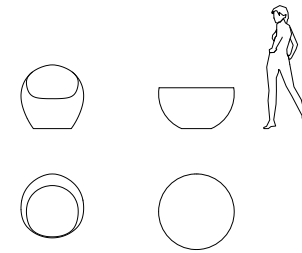

CUDDLY	FAMILY
L: 828 mm	Ø: 960 mm
W: 845 mm	H: 520 mm
H: 830 mm	W: 695 kg
W: 660 kg	



GLOSSY CONCRETE /
CEMENTO GLOSSY



WHITE GRANITE /
GRANITO BIANCO









FUNNY /

MATOUŠ HOLÝ

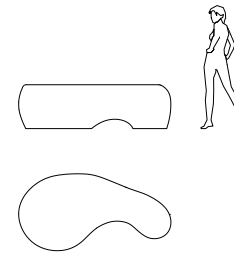

L: 2013 mm
D: 1017 mm
H: 580 mm
W: 1880 kg

MATERIALS: WHITE GRANITE OR GLOSSY CONCRETE.
FINISHING: VARNISHED WITH ACRYLIC POLYURETHANE PAINT ANTI UV.

MATERIALI: GRANITO BIANCO O CEMENTO GLOSSY.
FINITURA: VERNICIATURA ACRIL-POLIURETANICA ANTI UV.

GLOSSY CONCRETE /
CEMENTO GLOSSY



WHITE GRANITE /
GRANITO BIANCO







HAPPY /

MATOUŠ HOLÝ

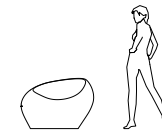

L: 960 mm
D: 655 mm
H: 662 mm
W: 505 kg

MATERIALS: WHITE GRANITE OR GLOSSY CONCRETE.
FINISHING: VARNISHED WITH ACRYLIC POLYURETHANE PAINT ANTI UV.

MATERIALI: GRANITO BIANCO O CEMENTO GLOSSY.
FINITURA: VERNICIATURA ACRIL-POLIURETANICA ANTI UV.

GLOSSY CONCRETE /
CEMENTO GLOSSY



WHITE GRANITE /
GRANITO BIANCO





HARMONY /

MATOUŠ HOLÝ

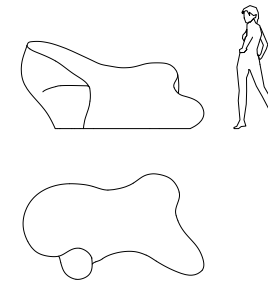

L: 2390 mm
D: 1400 mm
H: 1080 mm
W: 2525 kg

MATERIALS: WHITE GRANITE OR GLOSSY CONCRETE.
FINISHING: VARNISHED WITH ACRYLIC POLYURETHANE PAINT ANTI UV.

MATERIALI: GRANITO BIANCO O CEMENTO GLOSSY.
FINITURA: VERNICIATURA ACRIL-POLIURETANICA ANTI UV.



GLOSSY CONCRETE /
CEMENTO GLOSSY



WHITE GRANITE /
GRANITO BIANCO









POLARY /

BELLITALIA® DESIGN DEPARTMENT

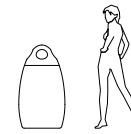

Ø: 610 mm
H: 1100 mm
W: 272 Kg

MATERIALS: WHITE GRANITE OR GLOSSY CONCRETE WITH STEEL OR STAINLESS STEEL COVERING.

FINISHING: VARNISHED WITH ACRYLIC POLYURETHANE PAINT ANTI UV.

MATERIALI: GRANITO BIANCO O CEMENTO GLOSSY, CON COPERTURA IN ACCIAIO O IN ACCIAIO INOX.

FINITURA: VERNICIATURA ACRIL-POLIURETANICA ANTI UV.

GLOSSY CONCRETE /
CEMENTO GLOSSY



WHITE GRANITE /
GRANITO BIANCO









MATERIALS /
MATERIALI

FINISHING /
FINITURE

ACCESSORIES MATERIALS /
MATERIALI ACCESSORI

TECHNICAL DETAILS /
DETTAGLI TECNICI

GREY CONCRETE / CEMENTO GRIGIO



POLISHED /
LEVIGATO



BUSH HAMMERED /
BOCCIARDATO



SANDBLASTED /
SABBIATO

- **FEATURES:** TO PRODUCE GREY CONCRETE, PORTLAND CEMENT IS USED WITH INERT MINERALS FROM THE LOCAL QUARRIES.
- **TREATMENT:** ALL VISIBLE SURFACES ARE COVERED WITH A TRANSPARENT PROTECTIVE ANTI-DECAY COATING THAT PREVENTS WATER ABSORPTION ENSURING INALTERABILITY OF THE PRODUCT OVER TIME WHILE PROTECTING IT FROM EROSION BY AIR POLLUTANTS AND FROM THE FORMATION OF FROST AND MOULD. UPON REQUEST THE GOODS CAN BE TREATED WITH NANOTECHNOLOGY PRODUCTS OR WITH AN ANTI-GRAFFITI VARNISH, WHICH FACILITATES THE REMOVAL OF ANY SIGNS OF VANDALISM CARRIED OUT WITH PERMANENT MARKERS OR SPRAYS.
- **MAINTENANCE :** THE GREY CONCRETE CONGLOMERATE IS AN EXTREMELY DURABLE MATERIAL THAT REQUIRES MINIMAL MAINTENANCE. THIS PURELY CONSISTS OF THE TREATMENT OF THE SURFACE WITH VERY FINE ABRASIVE PAPER AND IN THE RE-APPLICATION OF ONE OR MORE COATS OF THE ACRYLIC PROTECTIVE VARNISH. IN CASE OF ACCIDENTAL CHIPPING OF THE ARTIFACTS MADE OF CONGLOMERATE, **BELLITALIA®** PROVIDES A REPAIR KIT CONSISTING OF A BI-COMPONENT MATERIAL THE SAME AS THE ORIGINAL. TO APPLY SIMPLY CLEAN THE CHIPPED AREA, REMOVING ANY DUST OR DEPOSITS AND THEN APPLY THE PASTE-COMPONENT. ONCE THE DRYING TIME IS COMPLETED, IT IS SUFFICIENT TO APPLY A COAT OF TRANSPARENT ACRYLIC ANTI-DECAY VARNISH.



- **CARATTERISTICHE:** PER REALIZZARE IL CALCESTRUZZO GRIGIO SI UTILIZZANO CEMENTI PORTLAND E INERTI PROVENIENTI DALLE CAVE LOCALI.
- **TRATTAMENTO:** TUTTE LE SUPERFICI A VISTA SONO TRATTATE CON VERNICI PROTETTIVE TRASPARENTI ANTIDEGRADO CHE IMPEDISCONO L'ASSORBIMENTO DELL'ACQUA ASSICURANDO UN'INALTERABILITÀ DEL PRODOTTO NEL TEMPO E PROTEGGENDOLO DALL'EROSIONE DA PARTE DEGLI AGENTI ATMOSFERICI INQUINANTI E DALLA FORMAZIONE DI GHIACCIO E MUFFE. SU RICHIESTA I MANUFATTI POSSONO ESSERE TRATTATI CON PRODOTTI NANOTECONOLOGICI O CON VERNICI ANTI GRAFFITI, CHE FACILITANO LA RIMOZIONE DI EVENTUALI SEGNI DI VANDALISMO EFFETTUATI CON SPRAY O PENNARELLI INDELEBILI.
- **MANUTENZIONE:** IL CONGLOMERATO DEL TIPO CALCESTRUZZO GRIGIO È UN MATERIALE ESTREMAMENTE DURATURO CHE RICHIEDE UNA MANUTENZIONE MINIMA.

ESSA CONSISTE NEL TRATTAMENTO DELLA SUPERFICIE CON CARTE ABRASIVE FINISSIME E NELLA RIAPPLICAZIONE DI UNA O PIÙ MANI DI VERNICE ACRILICA PROTETTIVA. IN CASO DI SCHEGGIATURA ACCIDENTALE DEI MANUFATTI IN CONGLOMERATO, **BELLITALIA®** FORNISCE UN KIT DI RIPARAZIONE COSTITUITO DA MATERIALE BICOMPONENTE DELLO STESSO TIPO DI INERTE DEL PRODOTTO. PER APPLICARLO È SUFFICIENTE PULIRE LA PARTE SCHEGGIATA RIMUOVENDO EVENTUALE POLVERE O DEPOSITI E POI APPLICARE LA PASTA BICOMPONENTE. UNA VOLTA TRASCORSO IL TEMPO DI ASCIUGATURA È SUFFICIENTE APPLICARE UNA MANO DI VERNICE ACRILICA TRASPARENTE ANTIDEGRADO.

WHITE GRANITE / GRANITO BIANCO

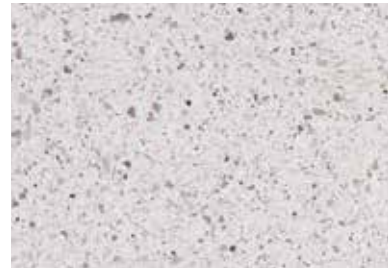

POLISHED /
LEVIGATO



BUSH HAMMERED /
BOCCIARDATO



SANDBLASTED /
SABBIATO

- **FEATURES:** TO PRODUCE WHITE GRANITE, WHITE PORTLAND CEMENT IS USED WITH WHITE INERT MATERIAL FROM THE LOCAL QUARRIES.
- **TREATMENT:** ALL VISIBLE SURFACES ARE COVERED WITH A TRANSPARENT PROTECTIVE ANTI-DECAY COATING THAT PREVENT WATER ABSORPTION ENSURING INALTERABILITY OF THE PRODUCT OVER TIME AND PROTECTING IT FROM EROSION BY AIR POLLUTANTS AND FROM THE FORMATION OF FROST AND MOULD. ON REQUEST, THE GOODS CAN BE TREATED WITH NANOTECHNOLOGY PRODUCTS OR TREATED WITH AN ANTI-GRAFFITI VARNISH, WHICH FACILITATES THE REMOVAL OF ANY SIGNS OF VANDALISM CARRIED OUT WITH SPRAYS OR PERMANENT MARKERS.
- **MAINTENANCE:** THE WHITE GRANITE CONGLOMERATE IS AN EXTREMELY DURABLE MATERIAL THAT REQUIRES MINIMAL MAINTENANCE. THIS PURELY CONSISTS OF THE TREATMENT OF THE SURFACE WITH VERY FINE ABRASIVE PAPER AND IN THE RE-APPLICATION OF ONE OR MORE COATS OF ACRYLIC PROTECTIVE VARNISH. IN CASE OF ACCIDENTAL CHIPPING OF THE ARTIFACTS MADE OF CONGLOMERATE, **BELLITALIA®** PROVIDES A REPAIR KIT CONSISTING OF A BI-COMPONENT MATERIAL THE SAME AS THE ORIGINAL. TO APPLY SIMPLY CLEAN THE CHIPPED AREA, REMOVING ANY DUST OR DEPOSITS AND THEN APPLY THE PASTE-COMPONENT. ONCE THE DRYING TIME IS COMPLETED, IT IS SUFFICIENT TO APPLY A COAT OF TRANSPARENT ACRYLIC ANTI-DECAY VARNISH.



- **CARATTERISTICHE:** PER REALIZZARE IL GRANITO BIANCO SI UTILIZZANO CEMENTI BIANCHI PORTLAND E INERTI BIANCHI PROVENIENTI DALLE CAVE LOCALI.
- **TRATTAMENTO:** TUTTE LE SUPERFICI A VISTA SONO TRATTATE CON VERNICI PROTETTIVE TRASPARENTI ANTIDEGRADO CHE IMPEDISCONO L'ASSORBIMENTO DELL'ACQUA ASSICURANDO UN'INALTERABILITÀ DEL PRODOTTO NEL TEMPO E PROTEGGENDOLO DALL'EROSIONE DA PARTE DEGLI AGENTI ATMOSFERICI INQUINANTI E DALLA FORMAZIONE DI GHIACCIO E MUFFE. SU RICHIESTA I MANUFATTI POSSONO ESSERE TRATTATI CON PRODOTTI NANOTECONOLOGICI O TRATTATI CON VERNICI ANTI GRAFFITI, CHE FACILITANO LA RIMOZIONE DI EVENTUALI SEGNI DI VANDALISMO EFFETTUATI CON SPRAY O PENNARELLI INDELEBILI.
- **MANUTENZIONE:** IL CONGLOMERATO DI TIPO GRANITO BIANCO È UN MATERIALE ESTREMAMENTE DURATURO CHE RICHIEDE UNA MANUTENZIONE MINIMA. ESSA CONSISTE NEL

TRATTAMENTO DELLA SUPERFICIE CON CARTE ABRASIVE FINISSIME E NELLA RIAPPLICAZIONE DI UNA O PIÙ MANI DI VERNICE ACRILICA PROTETTIVA. IN CASO DI SCHEGGIATURA ACCIDENTALE DEI MANUFATTI IN CONGLOMERATO, **BELLITALIA®** FORNISCE UN KIT DI RIPARAZIONE COSTITUITO DA MATERIALE BICOMPONENTE DELLO STESSO TIPO DI INERTE DEL PRODOTTO. PER APPLICARLO È SUFFICIENTE PULIRE LA PARTE SCHEGGIATA RIMUOVENDO EVENTUALE POLVERE O DEPOSITI E POI APPLICARE LA PASTA BICOMPONENTE. UNA VOLTA TRASCORSO IL TEMPO DI ASCIUGATURA È SUFFICIENTE APPLICARE UNA MANO DI VERNICE ACRILICA TRASPARENTE ANTIDEGRADO.

NATURAL MARBLE STONES

AGGREGATE /

AGGREGATO DI PIETRE DI MARMO NATURALI



WHITE CARRARA /
BIANCO CARRARA



BOTTICINO /
BOTTICINO

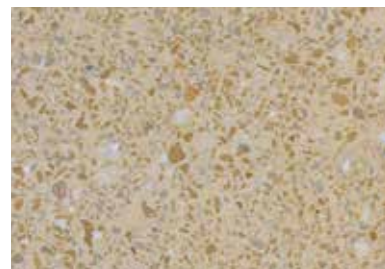

YELLOW MORI /
GIALLO MORI



VENEZIANO /
VENEZIANO

- **FEATURES:** TO PRODUCE THE MARBLE STONES CONGLOMERATE, WHITE PORTLAND CEMENT IS USED WITH INERT MATERIALS OF VARIOUS SIZES FROM ITALIAN MARBLE QUARRIES. THE DUST FROM THE SAME NATURAL STONE GIVES THE PRODUCTS ITS CHARACTERISTIC FINAL COLOUR.
- **TREATMENT:** ALL VISIBLE SURFACES ARE COVERED WITH A TRANSPARENT PROTECTIVE ANTI-DECAY COATING THAT PREVENT WATER ABSORPTION ENSURING INALTERABILITY OF THE PRODUCT OVER TIME AND PROTECT IT FROM EROSION BY ATMOSPHERIC POLLUTANTS AND BY THE FORMATION OF FROST AND MOULD. ON REQUEST, THE GOODS CAN BE TREATED WITH NANOTECHNOLOGY PRODUCTS OR WITH ANTI-GRAFFITI VARNISH, WHICH FACILITATES THE REMOVAL OF ANY SIGNS OF VANDALISM CARRIED OUT WITH PERMANENT MARKERS OR SPRAYS.
- **MAINTENANCE:** THE NATURAL MARBLE STONES CONGLOMERATE IS AN EXTREMELY DURABLE MATERIAL THAT REQUIRES MINIMAL MAINTENANCE. THIS PURELY CONSISTS OF THE TREATMENT OF THE SURFACE WITH VERY FINE ABRASIVE PAPER AND IN THE RE-APPLICATION OF ONE OR MORE COATS OF ACRYLIC PROTECTIVE VARNISH. IN CASE OF ACCIDENTAL CHIPPING OF THE ARTIFACTS MADE OF CONGLOMERATE, **BELLITALIA®** PROVIDES A REPAIR KIT CONSISTING OF A BI-COMPONENT MATERIAL THE SAME AS THE ORIGINAL. TO APPLY SIMPLY CLEAN THE CHIPPED AREA, REMOVING ANY DUST OR DEPOSITS AND THEN APPLY THE PASTE-COMPONENT. ONCE THE DRYING TIME IS COMPLETED, IT IS SUFFICIENT TO APPLY A COAT OF TRANSPARENT ACRYLIC ANTI-DECAY VARNISH.



- **CARATTERISTICHE:** PER REALIZZARE IL CONGLOMERATO DI PIETRE DI MARMO SI UTILIZZANO CEMENTI BIANCHI PORTLAND E INERTI DI VARIE PEZZATURE PROVENIENTI DALLE CAVE ITALIANE DEL MARMO. E' LA POLVERE STESSA DELLA PIETRA NATURALE A CONFERIRE AL MANUFATTO IL CARATTERISTICO COLORE FINALE.
- **TRATTAMENTO:** TUTTE LE SUPERFICI A VISTA SONO TRATTATE CON VERNICI PROTETTIVE TRASPARENTI ANTIDEGRADO CHE IMPEDISCONO L'ASSORBIMENTO DELL'ACQUA ASSICURANDO UN'INALTERABILITÀ DEL PRODOTTO NEL TEMPO E PROTEGGENDOLO DALL'EROSIONE DA PARTE DEGLI AGENTI ATMOSFERICI INQUINANTI E DALLA FORMAZIONE DI GHIACCIO E MUFFE. SU RICHIESTA I MANUFATTI POSSONO ESSERE TRATTATI CON PRODOTTI NANOTECONOLOGICI O CON VERNICI ANTI GRAFFITI, CHE FACILITANO LA RIMOZIONE DI EVENTUALI



RED VERONA /
ROSSO VERONA



PORPHYRY /
PORFIDO



GREEN ALPS /
VERDE ALPI



BLACK EBONY /
NERO EBANO

SEGNI DI VANDALISMO EFFETTUATI CON SPRAY O PENNARELLI INDELEBILI.

- **MANUTENZIONE:** IL CONGLOMERATO DEL TIPO PIETRE DI MARMO NATURALI È UN MATERIALE ESTREMAMENTE DURATURO CHE RICHIEDE UNA MANUTENZIONE MINIMA. ESSA CONSISTE NEL TRATTAMENTO DELLA SUPERFICIE CON CARTE ABRASIVE FINISSIME E NELLA RIAPPLICAZIONE DI UNA O PIÙ MANI DI VERNICE ACRILICA PROTETTIVA. IN CASO DI SCHEGGIATURA ACCIDENTALE DEI MANUFATTI IN CONGLOMERATO, **BELLITALIA®** FORNISCE UN KIT DI RIPARAZIONE COSTITUITO DA MATERIALE BICOMPONENTE DELLO STESSO TIPO DI INERTE DEL PRODOTTO. PER APPLICARLO È SUFFICIENTE PULIRE LA PARTE SCHEGGIATA RIMUOVENDO EVENTUALE POLVERE O DEPOSITI E POI APPLICARE LA PASTA BICOMPONENTE. UNA VOLTA TRASCORSO IL TEMPO DI ASCIUGATURA È SUFFICIENTE APPLICARE UNA MANO DI VERNICE ACRILICA TRASPARENTE ANTIDEGRADO.

ULTRATENSE CONCRETE® / L'ULTRALEGGERO

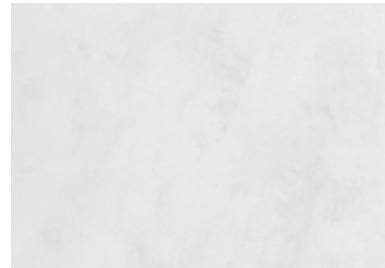

WHITE /
BIANCO



CHARCOAL GREY /
ANTRACITE

- **FEATURES:** THIS NEW MATERIAL IS THE RESULT OF CONTINUOUS RESEARCH AND INNOVATION BY THE TECHNICAL AND ENGINEERING DEPARTMENTS IN **BELLITALIA®** AND EMBODIES A CLOSE COLLABORATION WITH ONE OF THE MOST ADVANCED CENTRES FOR THE STUDY OF ENGINEERING MATERIALS: THE POLYTECHNIC UNIVERSITY OF MARCHE. LABORATORIES WITH THE LATEST EQUIPMENT AND A TEAM OF RESEARCHERS OF THE HIGHEST LEVEL, COMBINED WITH THE EXPERIENCE OF THE COMPANY, HAVE ENABLED US TO OBTAIN A UNIQUE FORMULA, WITH EXCELLENT CHARACTERISTICS OF UTILITY, STRENGTH, FINISHING AND SAFETY. THE MIXTURE IS DESIGNED TO WITHSTAND LOW TEMPERATURES AS WELL AS HIGHER ONES. SOME OF THE KEY FEATURES THAT MAKE THIS MATERIAL UNIQUE INCLUDE A BENDING STRENGTH OF UP TO EIGHT TIMES HIGHER THAN TRADITIONAL CEMENT AND A FINISHING THAT PERFECTLY COPIES THE MOULD.
- **TREATMENT:** ALL VISIBLE SURFACES ARE COATED WITH TRANSPARENT ACRYLIC ANTI-DECAY PAINT OR ON REQUEST WITH NANOTECHNOLOGY OR ANTI-STAIN PRODUCTS.
- **MAINTENANCE:** IT IS NECESSARY TO CLEAN THE PIECE THOROUGHLY WITH LOW PRESSURIZED WATER AND RE-APPLY THE PROTECTIVE VARNISH.



- **CARATTERISTICHE:** QUESTO NUOVO MATERIALE È FRUTTO DELLA CONTINUA RICERCA ED INNOVAZIONE DEI DIPARTIMENTI TECNICI E INGEGNERISTICI DI **BELLITALIA®** E SCATURISCE DA UNA STRETTA COLLABORAZIONE CON UNO DEI CENTRI PIÙ ALL'AVANGUARDIA PER LO STUDIO INGEGNERISTICO DEI MATERIALI: IL DIPARTIMENTO DI SCIENZE E INGEGNERIA DELLA MATERIA, DELL'AMBIENTE ED URBANISTICA DELL'UNIVERSITÀ POLITECNICA DELLE MARCHE. LABORATORI CON ATTREZZATURE DI ULTIMA GENERAZIONE E UN POOL DI RICERCATORI DI MASSIMO LIVELLO, UNITI ALL'ESPERIENZA DELL'AZIENDA, CI HANNO PERMESSO DI OTTENERE UNA FORMULA UNICA, CON ECCELLENTI CARATTERISTICHE DI LAVORABILITÀ, RESISTENZA, FINITURA, SICUREZZA. LA MISCELA È STATA STUDIATA PER RESISTERE ALLE BASSE TEMPERATURE COSÌ COME A QUELLE PIÙ ALTE. ALCUNE DELLE CARATTERISTICHE FONDAMENTALI CHE RENDONO UNICO QUESTO MATERIALE SONO LA RESISTENZA IN FLESSIONE FINO A OTTO VOLTE SUPERIORE AL CEMENTO TRADIZIONALE E UNA FINITURA CHE COPIA PERFETTAMENTE LO STAMPO.
- **TRATTAMENTO:** TUTTE LE SUPERFICI A VISTA SONO TRATTATE CON VERNICI ACRILICHE TRASPARENTI ANTIDEGRADO

O SU RICHIESTA CON PRODOTTI NANOTECONOLOGICI O ANTIMACCHIA.

- **MANUTENZIONE:** È NECESSARIO PULIRE IL MANUFATTO ACCURATAMENTE CON ACQUA IN PRESSIONE A BASSA AGGRESSIVITÀ E RIAPPLICARE IL PROTETTIVO.

FINISHING / FINITURE



- **POLISHING:** THE PIECE IS SUBJECTED TO MANUAL OR MECHANICAL POLISHING WITH ROBOTIC MACHINES THAT REMOVE THE SURFACE LAYER OF THE MATERIAL TO GIVE THE PRODUCT A SLEEK, SHINY AND BRIGHT LOOK.

- **LEVIGATURA:** IL MANUFATTO VIENE SOTTOPOSTO A LEVIGATURA MANUALE O MECCANICA CON MACCHINARI ROBOTIZZATI CHE RIMUOVONO LO STRATO SUPERFICIALE DEL MATERIALE PER CONFERIRE AL PRODOTTO UN ASPETTO ELEGANTE, LUCIDO E BRILLANTE.



- **BUSH HAMMERING:** THE BUSH HAMMERED FINISHING BREAKS THE SURFACE STONES, GIVING THE PRODUCT A ROUGH APPEARANCE THAT BRINGS OUT THE BEST OF THE FINE AGGREGATES THAT COMPOSE IT.

- **BOCCIARDATURA:** LA FINITURA MARTELLINATA ROMPE SUPERFICIALMENTE LE PIETRE, DONANDO AL MANUFATTO UN ASPETTO RUVIDO CHE FA RISALTARE AL MASSIMO GLI INERTI PREGIATI CHE LO COMPONGONO.



- **SANDBLASTING:** THE JET OF SAND USED FOR THIS FINISHING, REMOVING A VERY FINE LAYER OF THE MATERIAL, ALLOWS THE MOST UNIFORM SURFACE OF THE PRODUCT.

- **SABBIATURA:** IL GETTO DI SABBIA UTILIZZATO PER QUESTA FINITURA, ASPORTANDO UNA FINISSIMA PARTE DI MATERIALE, PERMETTE DI UNIFORMARE AL MASSIMO LA SUPERFICIE DEL PRODOTTO.

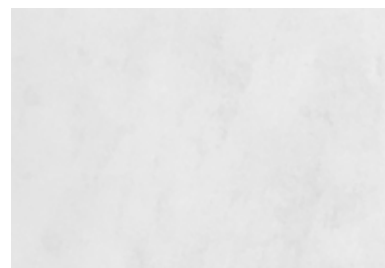

- **SMOOTH NATURAL:** THE SILKY FINISH OF THE PIECE JUST OUT OF THE MOULD.

- **LISCIO NATURALE:** È LA FINITURA SETOSA DEL MANUFATTO APPENA USCITO DALLO STAMPO.



- **GLOSSY PAINT:** EXCLUSIVELY FOR THE PRODUCTS OF THE ORGANIC LINE, BASED ON A TREATMENT OF A BI-COMPONENT BASE, IS CARRIED OUT USING AN INTENSE AND BRILLIANT COLOUR PAINT WITH ACRYLIC-POLYURETHANE UV-RESISTANT VARNISH, THE SAME USED FOR THE AUTOMOTIVE INDUSTRY.

- **VERNICIATURA GLOSSY:** IN ESCLUSIVA PER I PRODOTTI DELLA LINEA ORGANIC, SU UN TRATTAMENTO DI BASE BICOMPONENTE, VIENE EFFETTUATA UNA VERNICIATURA IN COLORI INTENSI E BRILLANTI CON PITTURE ACRIL-POLIURETANICHE ANTI UV, LE STESSO UTILIZZATE PER L'AUTOMOTIVE.

WOOD / LEGNO



ACCOYA /



MOVINGUI /



PINE /



OKOUMÈ /

- **FEATURES:** ONLY PRECIOUS WOODS THAT ARE HIGHLY RESISTANT ARE USED, SPECIFICALLY CHOSEN BASED ON THEIR CHARACTERISTICS OF EXTERNAL DURABILITY. THE FOLLOWING DIFFERENT TYPES OF ESSENCE ARE OFFERED ACCORDING TO THE DIFFERENT NEEDS OF THE CUSTOMER:
- ACCOYA®
- MOVINGUI
- PINE
- OKOUMÈ
- **TREATMENT:** THE WOOD TYPES OKOUMÈ, PINE AND MOVINGUI ARE FIRST PROTECTED WITH A WALNUT COLOUR WATER-BASED VARNISH THAT GUARANTEES THE DURABILITY AND RESISTANCE. LATER THEY ARE TREATED WITH WATER-BASED TRANSPARENT VARNISH. FOR THESE ESSENCES IT IS POSSIBLE TO REQUEST FOR AN ADDITIONAL COST AN ULTRA-RESISTANT COATING, LIKE SIKKENS, WHICH GREATLY EXTEND THE LIFETIME OF WOOD. FOR PINE WOOD ONLY, AT THE SPECIAL REQUEST OF THE CUSTOMER, THE THERMOWOOD® TREATMENT IS AVAILABLE, WHICH MAKES THE MATERIAL EVEN MORE RESISTANT TO DECAY IN OUTDOOR ENVIRONMENTS. INSTEAD, ACCOYA® WOOD UNDERGOES NO PAINTING, AS DIRECTED BY THE MANUFACTURER.
- **MAINTENANCE:** TO MAINTAIN A LIVING MATERIAL SUCH AS WOOD IN AESTHETICALLY OPTIMAL CONDITIONS IT IS ADVISABLE TO CARRY OUT MAINTENANCE ANNUALLY. IT IS BEST PERFORMED DURING THE SPRING SEASON AND CONSISTS OF A LIGHT SANDING OF THE SURFACE IN ORDER TO REMOVE ANY DIRT OR IMPERFECTIONS AND THE SUBSEQUENT RESTORATION OF THE PROTECTIVE TRANSPARENT COATING. THIS MAINTENANCE IS NOT REQUIRED FOR THE ACCOYA® WOOD AND THERMOWOOD® TREATMENT.

- **CARATTERISTICHE:** VENGONO IMPIEGATI SOLAMENTE LEGNI PREGIATI ED ALTAMENTE RESISTENTI, SPECIFICAMENTE SCELTI IN BASE ALLE LORO CARATTERISTICHE PER ESSERE DUREVOLI ALL'ESTERNO. A SECONDA DELLE DIVERSE ESIGENZE DEL CLIENTE VENGONO PROPOSTI DIVERSI TIPI DI ESSENZA:
- ACCOYA®
- MOVINGUI
- PINO
- OKOUMÈ
- **TRATTAMENTO:** I LEGNI DEL TIPO OKOUMÈ, PINO E MOVINGUI VENGONO PRIMA DI TUTTO PROTETTI CON VERNICI IMPREGNANTI AD ACQUA DI COLORE NOCE CHE NE GARANTISCONO LA DURATA E LA RESISTENZA. IN UN SECONDO MOMENTO VENGONO TRATTATI CON VERNICI AD ACQUA TRASPARENTI. SU RICHIESTA E CON SOVRAPPREZZO È POSSIBILE RICHIEDERE PER QUESTE ESSENZE UNA VERNICIATURA ULTRA RESISTENTE TIPO SIKKENS, CHE ALLUNGA DI MOLTO I TEMPI DI MANUTENZIONE DEL LEGNO. PER IL SOLO LEGNO DI PINO, SU RICHIESTA PARTICOLARE DEL CLIENTE, SI OFFRE IL TRATTAMENTO THERMOWOOD®, CHE RENDE IL MATERIALE ANCOR PIÙ RESISTENTE AL DEGRADO IN AMBIENTI ESTERNI. IL LEGNO ACCOYA® INVECE NON SUBISCE ALCUNA VERNICIATURA, COME DA INDICAZIONI DEL PRODUTTORE.
- **MANUTENZIONE:** PER MANTENERE UN MATERIALE VIVO COME IL LEGNO IN CONDIZIONI ESTETICAMENTE OTTIMALI È CONSIGLIABILE EFFETTUARE INTERVENTI DI MANUTENZIONE CON CADENZA ANNUALE. LE OPERAZIONI SI EFFETTUANO PREFERIBILMENTE DURANTE LA STAGIONE PRIMAVERILE E CONSISTONO NELL'ESEGUIRE UNA LEGGERA CARTEGGIATURA DELLA SUPERFICI COL FINE DI RIMUOVERE EVENTUALI DEPOSITI DI SPORCO O IMPERFEZIONI E NEL SUCCESSIVO RIPRISTINO DELLE VERNICI PROTETTIVE TRASPARENTI. TALI MANUTENZIONI NON SONO NECESSARIE PER I LEGNI ACCOYA® E THERMOWOOD®.

STONEWARE / GRES



LIGHT STONEWARE /
GRES CHIARO



DARK STONEWARE /
GRES SCURO

- **FEATURES:** PORCELAIN STONEWARE IS A VERY INEXPENSIVE MATERIAL THAT PROVIDES CONVENIENCE, DURABILITY AND HIGH AESTHETIC PRESENTING TECHNICAL CHARACTERISTICS AND COLOURS THAT REMAIN ALMOST UNCHANGED OVER TIME. IT IS A MATERIAL WITH AN EXCEPTIONAL LIFE CYCLE AND NO MAINTENANCE COSTS, IT IS LIGHT, FROST-RESISTANT, THERMAL-SHOCK RESISTANT, EASY TO CLEAN AND STERILISE WITH ECOLOGICAL PRODUCTS, HYPOALLERGENIC, RESISTANT TO MOULD, CHEMICALS AND CORROSION OF SALT, IT IS SUITABLE FOR BOTH NORMAL ENVIRONMENTAL CONDITIONS EITHER NEXT TO WATER OR UNDERWATER, RECYCLABLE AND ENVIRONMENTALLY FRIENDLY; IT IS A PRODUCT THAT FITS PERFECTLY INTO THE NEW COLLECTION AS A GREEN NATURE-FRIENDLY MATERIAL.
 - **MAINTENANCE:** SIMPLY WIPE THE SURFACE OF THE PRODUCT WITH A CLOTH AND DETERGENT.
- ▲
- **CARATTERISTICHE:** IL GRES PORCELLANATO È UN MATERIALE MOLTO ECONOMICO CHE GARANTISCE PRATICITÀ, RESISTENZA E UN'ALTA RESA ESTETICA PRESENTANDO CARATTERISTICHE TECNICHE E COLORI CHE RIMANGONO PRESSOCHÉ INALTERATI NEL TEMPO. E' UN MATERIALE DALL'ECCEZIONALE CICLO DI VITA E PRIVO DI COSTI DI MANUTENZIONE, È LEGGERO, INGELIVO, RESISTENTE AGLI SBALZI TERMICI, È FACILE DA PULIRE E STERILIZZARE ANCHE CON PRODOTTI ECOLOGICI, IPOALLERGENICO, RESISTENTE A MUFFE, A PRODOTTI CHIMICI E ALLA CORROSIONE DEL SALE, È IDONEO SIA A CONDIZIONI AMBIENTALI NORMALI CHE A CONTESTI PROSSIMI ALL'ACQUA O SOMMERSI. RICICLABILE ED ECOLOGICO RISULTA UN PRODOTTO CHE SI INSERISCE PERFETTAMENTE NEL NUOVO FILONE GREEN COME MATERIALE AMICO DELLA NATURA.
 - **MANUTENZIONE:** È SUFFICIENTE PULIRE LA SUPERFICIE DEI PRODOTTI CON UN PANNINO E DEL PRODOTTO DETERGENTE.

COPPER / RAME



COPPER /
RAME

- **FEATURES:** COPPER IS USED FOR DECORATIVE BANDS OR TO MAKE SOME PARTS OF THE PRODUCTS, AND CONSISTS OF PURE COPPER SHEETS.
 - **TREATMENT:** THE DECORATIVE BANDS ARE PAINTED WITH A TRANSPARENT PROTECTIVE COATING, WHILE THE CONSTITUENT PARTS OF THE PIECES ARE BURNISHED AND THEN PAINTED.
 - **MAINTENANCE:** SIMPLY WIPE THE SURFACE OF THE PRODUCT WITH A CLOTH AND DETERGENT.
- ▲
- **CARATTERISTICHE:** IL RAME UTILIZZATO PER LE FASCE DECORATIVE OPPURE PER REALIZZARE ALCUNE PARTI DEI PRODOTTI È COSTITUITO DA FOGLI DI RAME PURO.
 - **TRATTAMENTO:** LE FASCE DECORATIVE VENGONO VERNICIATE CON PITTURE PROTETTIVE TRASPARENTI, MENTRE LE PARTI COSTITUTIVE DEGLI ARTICOLI VENGONO BRUNITE E SUCCESSIVAMENTE VERNICIATE.
 - **MANUTENZIONE:** È SUFFICIENTE PULIRE LA SUPERFICIE DEI PRODOTTI CON UN PANNINO E DEL PRODOTTO DETERGENTE.

STAINLESS STEEL / STAINLESS STEEL



STAINLESS STEEL /
ACCIAIO INOX

- **FEATURES:** THE STAINLESS STEEL USED TO MAKE THE COMPONENTS OF OUR PRODUCTS IS EITHER THE 304L OR 316 TYPE. THE 316 IS RECOMMENDED FOR PRODUCTS THAT MAY BE POSITIONED IN CLOSE PROXIMITY TO AREAS OF EXTREME PRESENCE OF AGGRESSIVE COMPONENTS SUCH AS FERROUS CONTAMINATION OR SALINE.
- **TREATMENT:** THE STAINLESS STEEL ALWAYS UNDERGOES A SATIN FINISH TREATMENT AND SUBSEQUENT ELECTRO-POLISHING TO ENHANCE THE TECHNICAL AND VISUAL QUALITY.
- **MAINTENANCE:** SIMPLY WIPE THE SURFACE OF THE PRODUCT WITH A CLOTH AND DETERGENT.



- **CARATTERISTICHE:** L'ACCIAIO INOX UTILIZZATO PER REALIZZARE LE COMPONENTI DEI NOSTRI PRODOTTI È DEL TIPO 304L O 316. IL 316 È CONSIGLIATO IN CASO DI POSIZIONAMENTO DEI PRODOTTI IN PROSSIMITÀ DI AMBIENTI AD ALTA PRESENZA DI COMPONENTI AGGRESSIVI QUALI CONTAMINAZIONI FERROSE O SALINE.
- **TRATTAMENTO:** L'ACCIAIO INOX SUBISCE SEMPRE UN TRATTAMENTO DI SATINATURA E SUCCESSIVA ELETTRO-LUCIDATURA PER ESALTARNE LE QUALITÀ TECNICHE E VISIVE.
- **MANUTENZIONE:** È SUFFICIENTE PULIRE LA SUPERFICIE DEI PRODOTTI CON UN PANNO E DEL PRODOTTO DETERGENTE.

STEEL / ACCIAIO

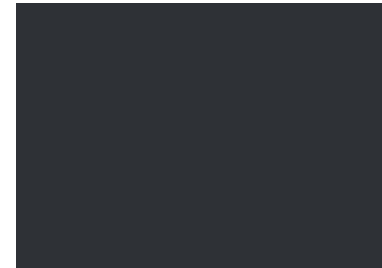

STEEL /
ACCIAIO

- **TREATMENTS:** STEEL IS ALWAYS TREATED BY A HOT DIP GALVANIZATION AND PAINTED NORMALLY WITH RAL 7021. ON REQUEST, AT AN EXTRA COST, THE PAINTING CAN BE CUSTOMISED WITH THE DESIRED RAL.
- **MAINTENANCE:** SIMPLY WIPE THE SURFACE OF THE PRODUCT WITH A CLOTH AND DETERGENT.



- **TRATTAMENTI:** L'ACCIAIO SUBISCE SEMPRE UN TRATTAMENTO DI ZINCATURA A CALDO E VERNICIATURA DI NORMA CON RAL 7021. SU RICHIESTA, CON SOVRAPPREZZO, È POSSIBILE PERSONALIZZARE LA VERNICIATURA CON IL RAL DESIDERATO.
- **MANUTENZIONE:** È SUFFICIENTE PULIRE LA SUPERFICIE DEI PRODOTTI CON UN PANNO E DEL PRODOTTO DETERGENTE.

TECHNICAL DETAILS / DETTAGLI TECNICI

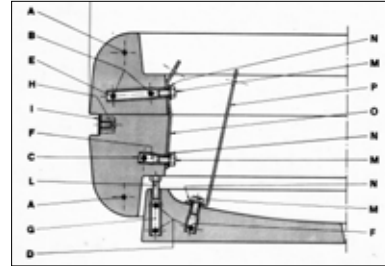

LEVELLING SYSTEM

THE LEVELLING SYSTEM IS DEFINITELY ONE OF THE MAIN PATENTED FUNCTIONAL SYSTEMS THAT HAS MADE **BELLITALIA®** PRODUCTS FAMOUS. IT ALLOWS COMPENSATION FOR THE SLOPE OF THE GROUND BY UP TO A MAXIMUM OF 6%, OBTAINING A LEVEL EFFECT FROM A VISUAL STANDPOINT.



WATER RESERVE SYSTEM AND OVERFLOW DISCHARGE

ANOTHER IMPORTANT PATENT THAT HAS ALLOWED SUCH A WIDE SPREAD OF **BELLITALIA®** PLANTERS OVER THE YEARS IS THE SYSTEM OF WATER SUPPLY AND DRAIN OVERFLOW, APPLIED TO ALL **BELLITALIA®** PLANTERS.

TO ENSURE A PLANT'S LONG LIFE, THE COMBINED SYSTEM OF WATER SUPPLY ENSURES A CONTINUOUS HYDRATION OF THE ROOTS AND THEIR AERATION, WHILE THE DISCHARGE OF THE OVERFLOW IS DESIGNED FOR THE ELIMINATION OF EXCESS WATER, WHICH HELPS PREVENT ROT.



HANDLING

EACH PRODUCT IS DESIGNED SO AS TO BE EASILY AND SAFELY HANDLED BY STRAPS OR CHAINS. FOR THIS, BUSHES ARE PROVIDED FOR THE MOVEMENT FOR EACH INDIVIDUAL PRODUCT. AFTER THE PLACEMENT, THEY ARE COVERED WITH A **BELLITALIA®** PLATE.



PACKAGING

THE PRODUCTS ARE SHIPPED ON PALLETS IN ORDER TO FACILITATE THE UNLOADING BY THE CUSTOMER AND PACKED WITH CORNER PROTECTORS AND SPACERS IN ORDER TO PROTECT THEM DURING TRANSPORT.

SISTEMA DI LIVELLAMENTO

UNO DEI PRINCIPALI SISTEMI FUNZIONALI BREVETTATI CHE HANNO RESO FAMOSI I PRODOTTI DI **BELLITALIA®**, È SICURAMENTE IL SISTEMA DI LIVELLAMENTO. ESSO PERMETTE DI COMPENSARE LA PENDENZA DEL TERRENO FINO AD UN MASSIMO DEL 6% OTTENENDO UN EFFETTO PIANO DA UN PUNTO DI VISTA VISIVO.

SISTEMA DI RISERVA D'ACQUA E SCARICO DEL TROPPO-PIENO

ALTRO IMPORTANTE BREVETTO CHE HA PERMESSO UNA COSÌ AMPIA DIFFUSIONE DELLE FIORIERE **BELLITALIA®** NEGLI ANNI, È IL SISTEMA DI RISERVA D'ACQUA E SCARICO DEL TROPPO PIENO, APPLICATO A TUTTE LE FIORIERE **BELLITALIA®**.

PER GARANTIRE UNA LUNGA VITA A PIANTE E FIORI, IL SISTEMA COMBINATO DI RISERVA D'ACQUA GARANTISCE UN'IDRATAZIONE CONTINUA DELLE RADICI E LA LORO AERAZIONE, MENTRE LO SCARICO DEL TROPPO PIENO È PENSATO PER L'ELIMINAZIONE DELL'ACQUA IN ECCESSO, CHE NE EVITA LA MARCESCENZA.

MOVIMENTAZIONE

OGNI PRODOTTO È PROGETTATO IN MODO DA POTER ESSERE FACILMENTE MOVIMENTATO IN SICUREZZA TRAMITE FASCE O CATENE. PER QUESTO SONO PREVISTE BOCCOLE PER LA MOVIMENTAZIONE PER OGNI SINGOLO ARTICOLO. UNA VOLTA TERMINATO IL POSIZIONAMENTO, ESSE VENGONO COPERTE CON UNA TARGHETTA **BELLITALIA®**.

IMBALLO

I PRODOTTI VENGONO SPEDITI SU PALLETT IN MODO DA FACILITARNE LO SCARICO DA PARTE DEL CLIENTE E IMBALLATI CON PROTEZIONI ANGOLARI E SPESSORI IN MODO DA PROTEGGERLI DURANTE I TRASPORTI.

CONCEPT:

BELLITALIA DESIGN DEPARTMENT
 IVAN DEL PONTE
 MARTINA AZZURRA BERTAGNO
 MATTEO CESCHINI
 MATTEO ZAMBELLI
 STUDIO C+S ARCHITECTS

PHOTOGRAPHY:

ARCH. BELLITALIA
 FRANCESCO VASCELLARI
 JORGE MORO
 PIETRO SAVORELLI
 ROBERTA DE MIN

FINITO DI STAMPARE NEL 2015 PRESSO LA CASA EDITRICE LA
 GRAFICA DI MORI (TN)



© 2015 BELLITALIA S.R.L.
 INFO@BELLITALIA.NET
 I-32014 PONTE NELLE ALPI (BL)



ALL WEIGHTS AND MEASURES INDICATED IN THIS CATALOGUE
 ARE PURELY INDICATIVE. BELLITALIA® S.R.L. RESERVES THE
 RIGHT TO MAKE THEIR OWN PRODUCTS, WITHOUT THE NEED FOR
 ANY NOTICE FOR ANY CURRENT ORDERS, MAKE ANY CHANGES
 CONSIDERED NECESSARY TO IMPROVE QUALITY AND DURABILITY,
 DIMENSIONAL AND STRUCTURAL.
 ALL MATERIALS SHOWN IN THE CATALOGUE IS THE EXCLUSIVE
 PROPERTY OF BELLITALIA®.



TUTTI I PESI E LE MISURE INDICATI IN QUESTO CATALOGO SONO
 DA RITENERSI PURAMENTE INDICATIVI.

BELLITALIA® S.R.L. SI RISERVA DI APPORTARE AI PROPRI
 PRODOTTI, SENZA NECESSITÀ DI ALCUN AVVISO ANCHE PER
 EVENTUALI ORDINI IN CORSO, QUALSIASI MODIFICA RITENUTA
 UTILE AL MIGLIORAMENTO QUALITATIVO DEGLI STESSI,
 DIMENSIONALE COME STRUTTURALE.



TUTTO IL MATERIALE RAFFIGURATO A CATALOGO È DI PROPRIETÀ
 ESCLUSIVA DI **BELLITALIA®** S.R.L.

BELLITALIA® S.R.L. MANTIENE TUTTI I DIRITTI E LA PROPRIETÀ
 ARTISTICA E LETTERARIA; NESSUNA PARTE DI QUESTA
 PUBBLICAZIONE PUÒ ESSERE RIPRODOTTA, ARCHIVIATA IN UN
 DATABASE O TRASMESSA IN QUALSIASI FORMA O CON QUALSIASI
 MEZZO, SALVO CONSENSO.